

- 1. LNK
- 2. SCH
- 3. SCH
- 4. SCH
- 5. SCH
- 6. SCH
- 7. SCH
- 8. SCH
- 9. SCH
- 10. SCH
- 11. SCH
- 12. SCH
- 13. SCH
- 14. SCH
- 15. SCH
- 16. SCH
- 17. SCH
- 18. SCH
- 19. SCH
- 20. SCH
- 21. SCH
- 22. SCH
- 23. SCH
- 24. SCH
- 25. SCH
- 26. SCH
- 27. SCH
- 28. SCH
- 29. SCH
- 30. SCH
- 31. SCH
- 32. SCH
- 33. SCH

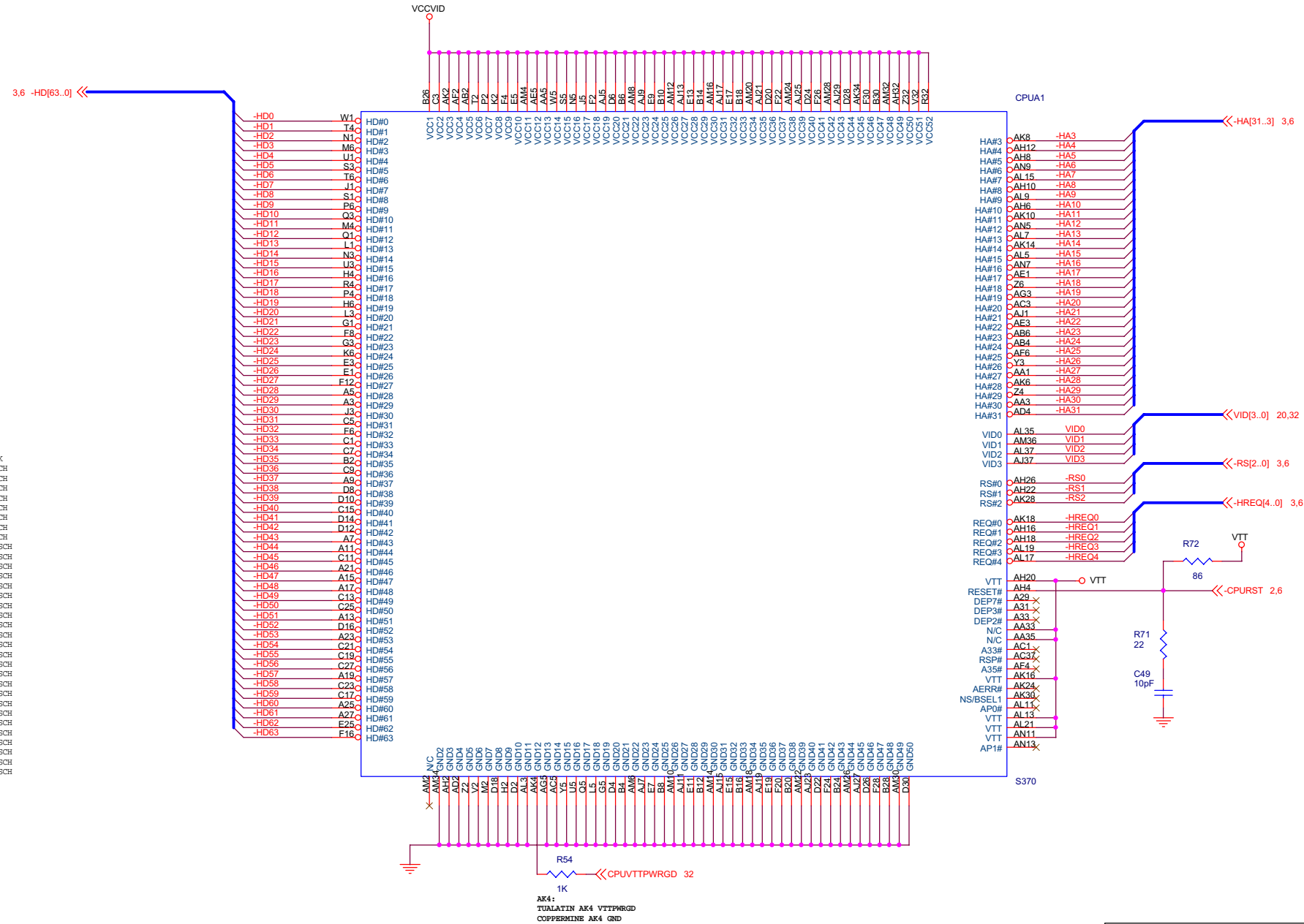

JET WAY INFORMATION		
Title	370-1 PIN SOCKET	
Size	Document Number	Rev
B	J615TCF/J615TCS	A
Date:	Friday, October 12, 2001	Sheet 1 of 33

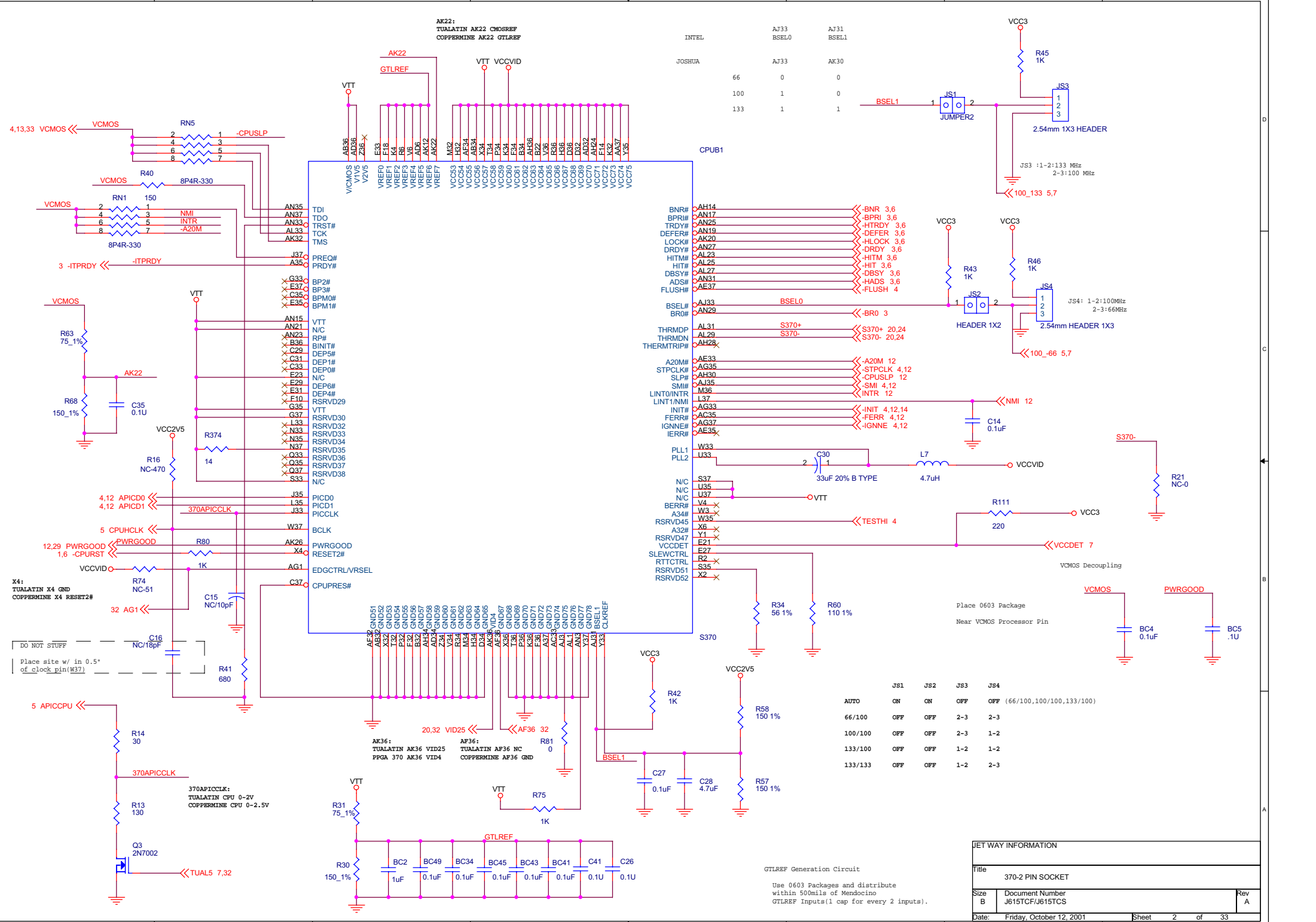

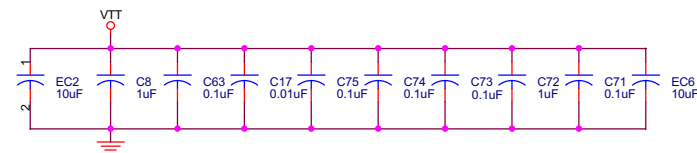
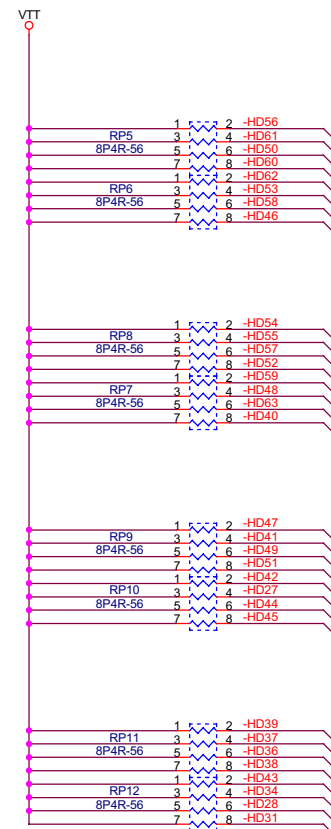
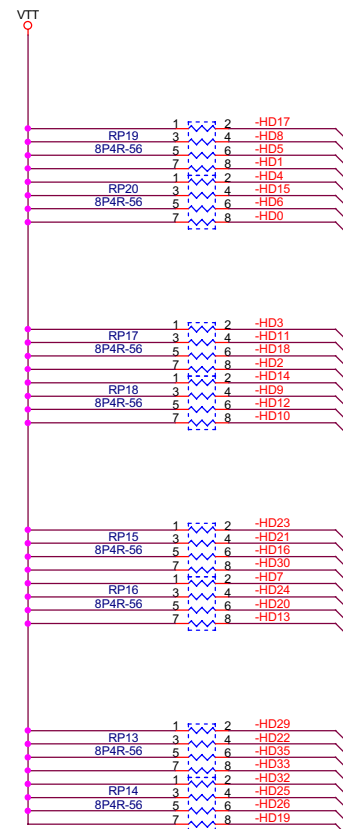
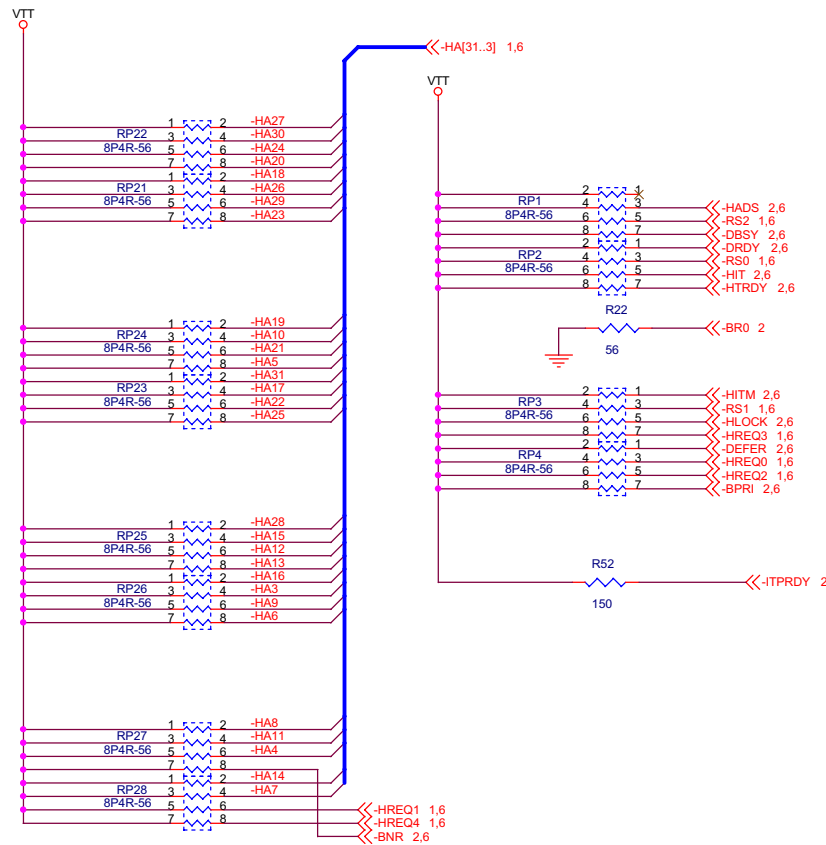

JET WAY INFORMATION		
Title	GTL Termination	
Size	Document Number	Rev
B	J615TCF/J615TCS	A
Date:	Friday, October 12, 2001	Sheet 3 of 33

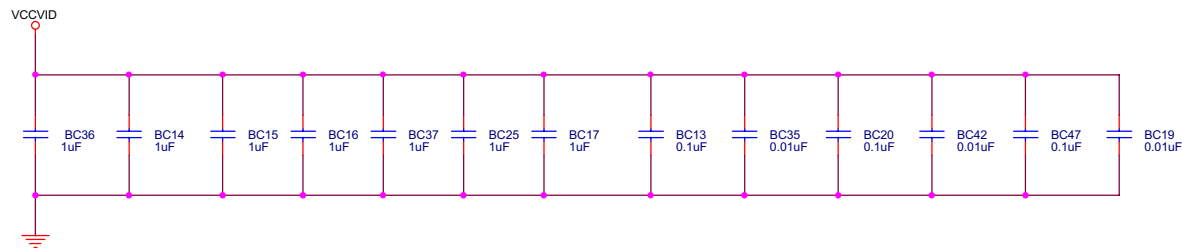

FOR CPU

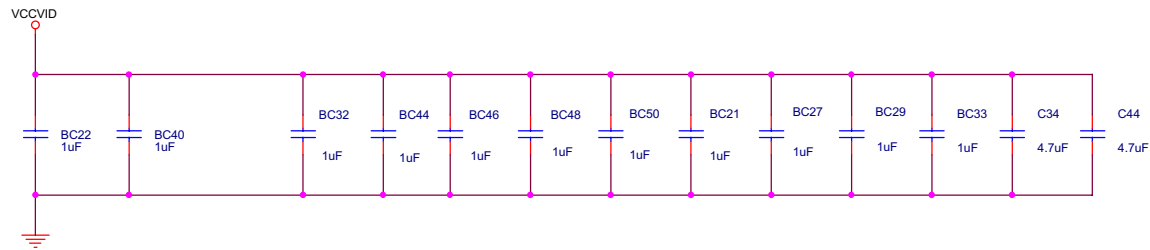

FOR CPU

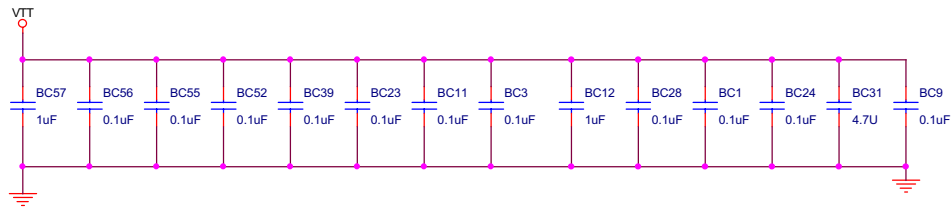

FOR CPU VTT

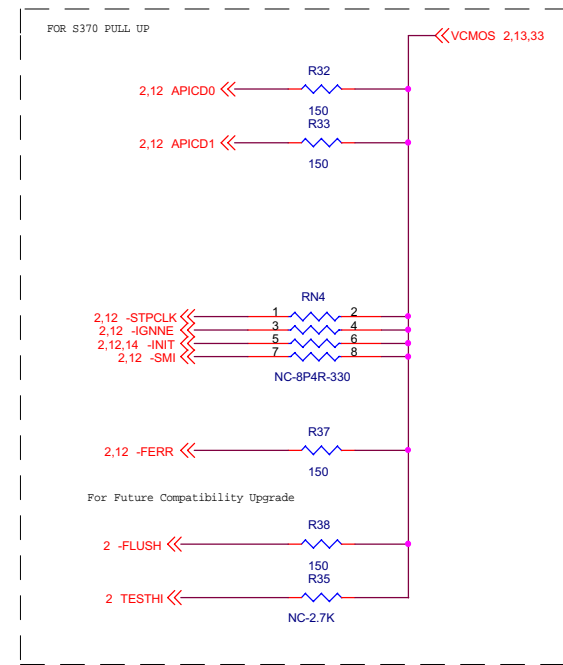

JET WAY INFORMATION		
Title	370-pin Socket Decoupling	
Size	Document Number	Rev
B	J615TCF/J615TCS	A
Date:	Friday, October 12, 2001	Sheet 4 of 33

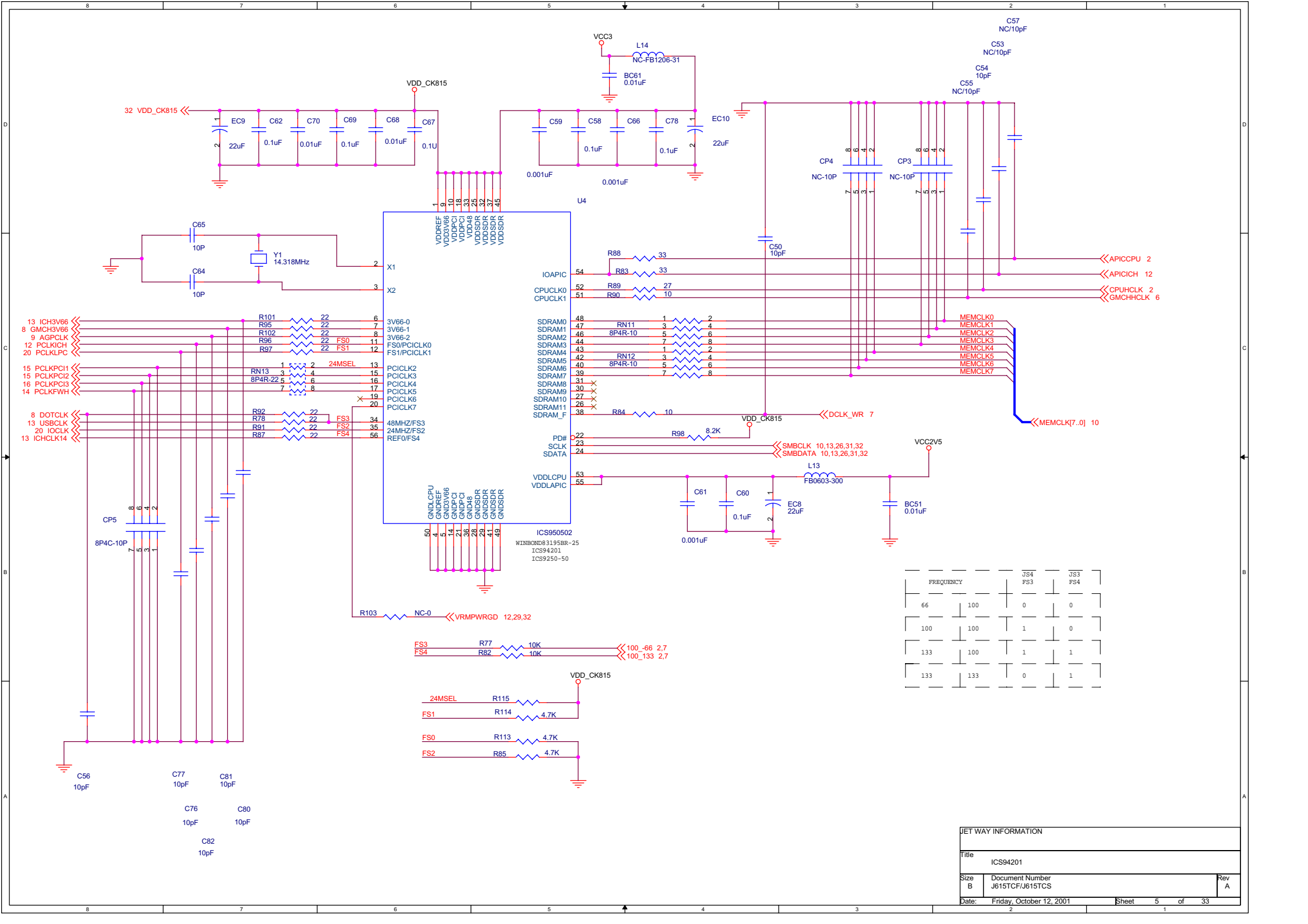

FREQUENCY	J54 FS3	J53 FS4
66	100	0
100	100	1
133	100	1
133	133	0

JET WAY INFORMATION		
Title	ICS94201	
Size	Document Number	Rev
B	J615TCF/J615TCS	A
Date:	Friday, October 12, 2001	Sheet 5 of 33



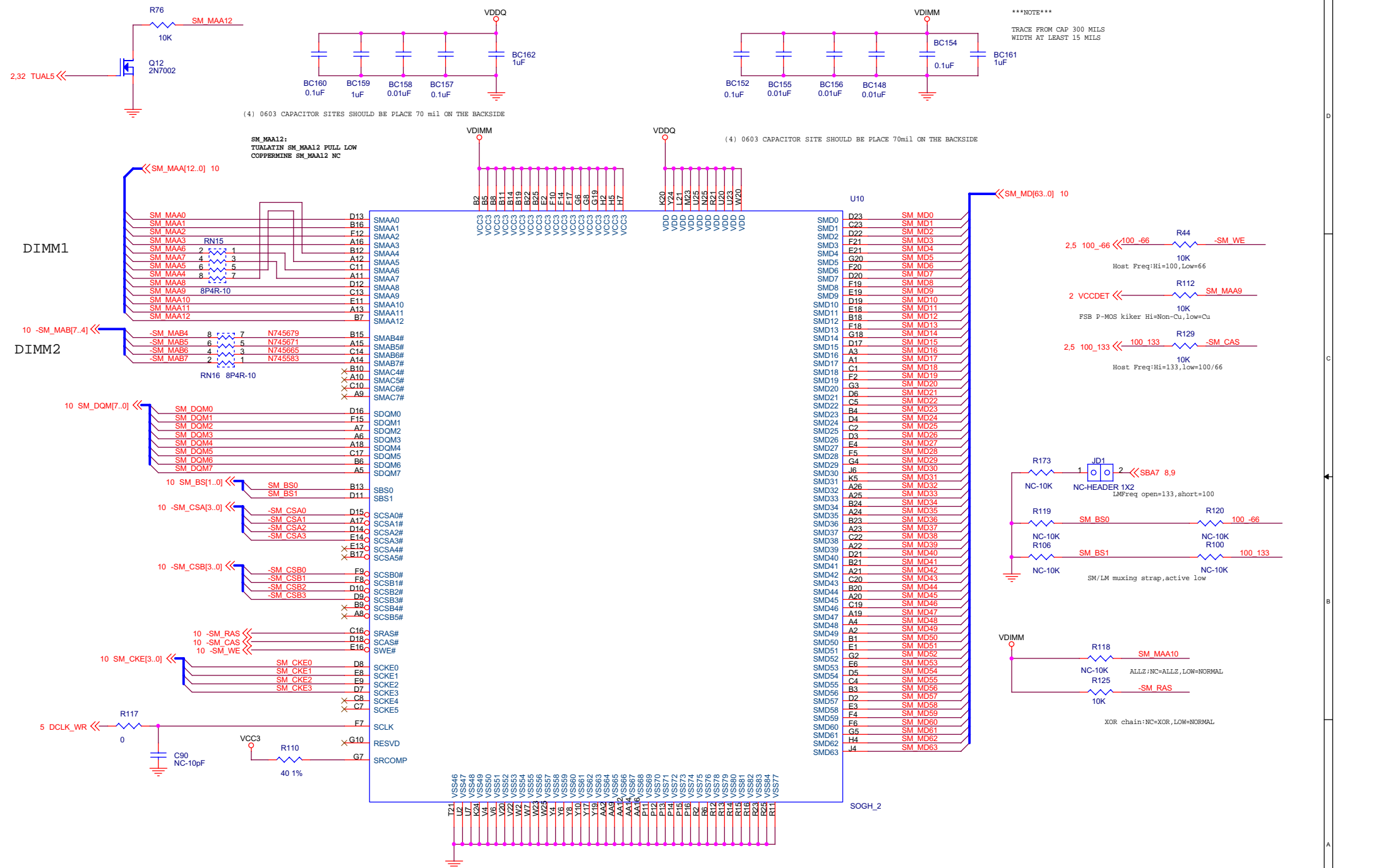

\*\*\*NOTE\*\*\*  
TRACE FROM CAP 300 MILS  
WIDTH AT LEAST 15 MILS

(4) 0603 CAPACITOR SITES SHOULD BE PLACE 70 mil ON THE BACKSIDE

(4) 0603 CAPACITOR SITE SHOULD BE PLACE 70mil ON THE BACKSIDE

SM\_MAA12:  
TUALATIN SM\_MAA12 PULL LOW  
COPPERMINE SM\_MAA12 NC

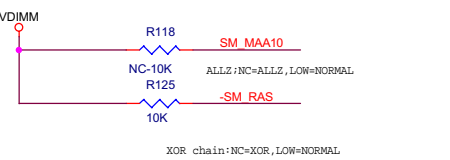
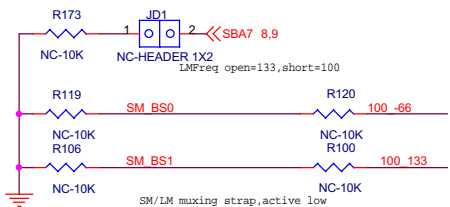

JET WAY INFORMATION		
Title GMCH,Part2:System Memory and Hub		
Size B	Document Number J615TCF/J615TCS	Rev A
Date: Friday, October 12, 2001	Sheet 7	of 33

Use surface mount caps placed close as possible to power pins with short, wide direct connections.

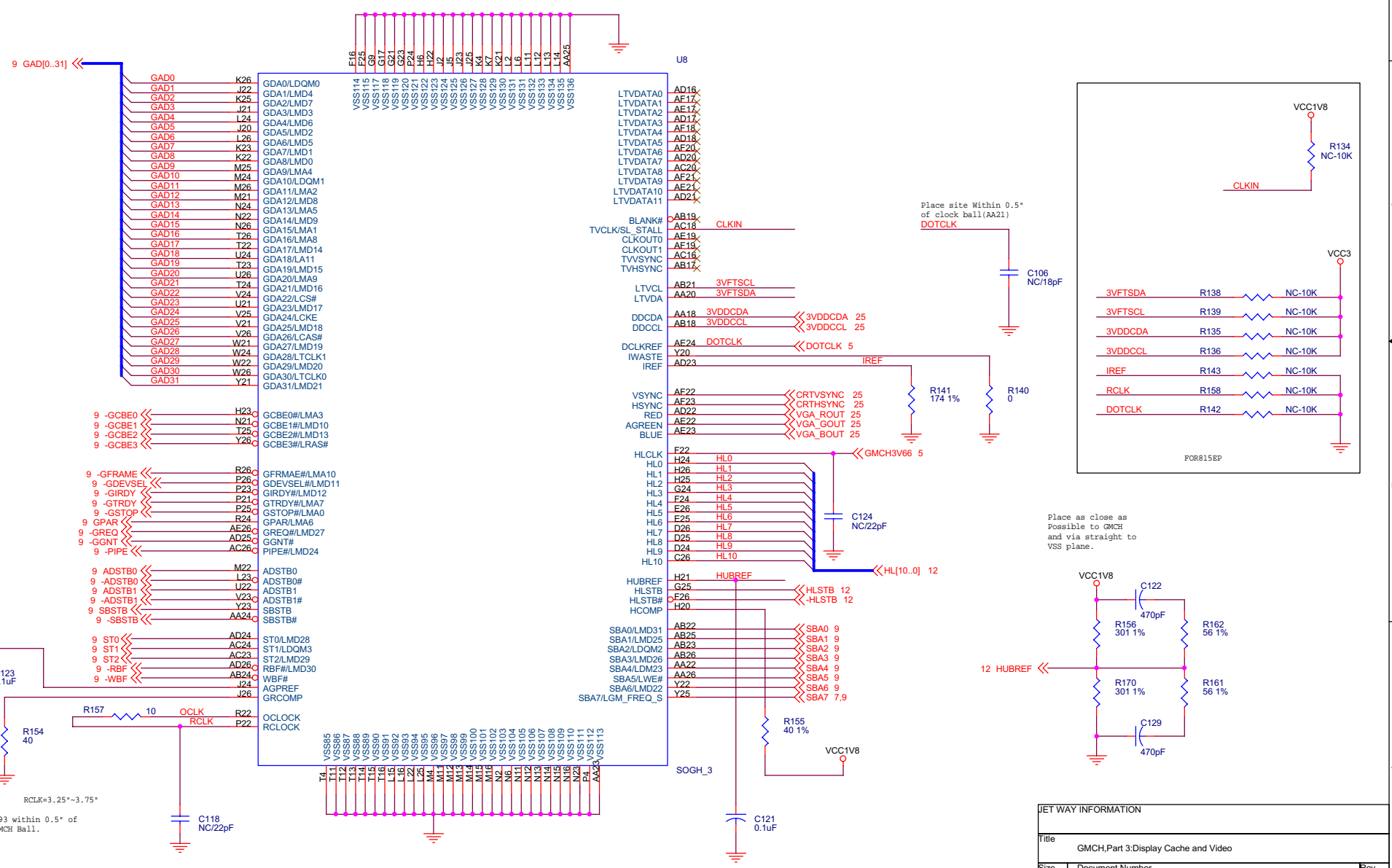

JET WAY INFORMATION		
Title	GMCH,Part 3:Display Cache and Video	
Size	Document Number	Rev
B	J615TCF/J615TCS	A
Date:	Friday, October 12, 2001	Sheet 8 of 33

# APG\_4X

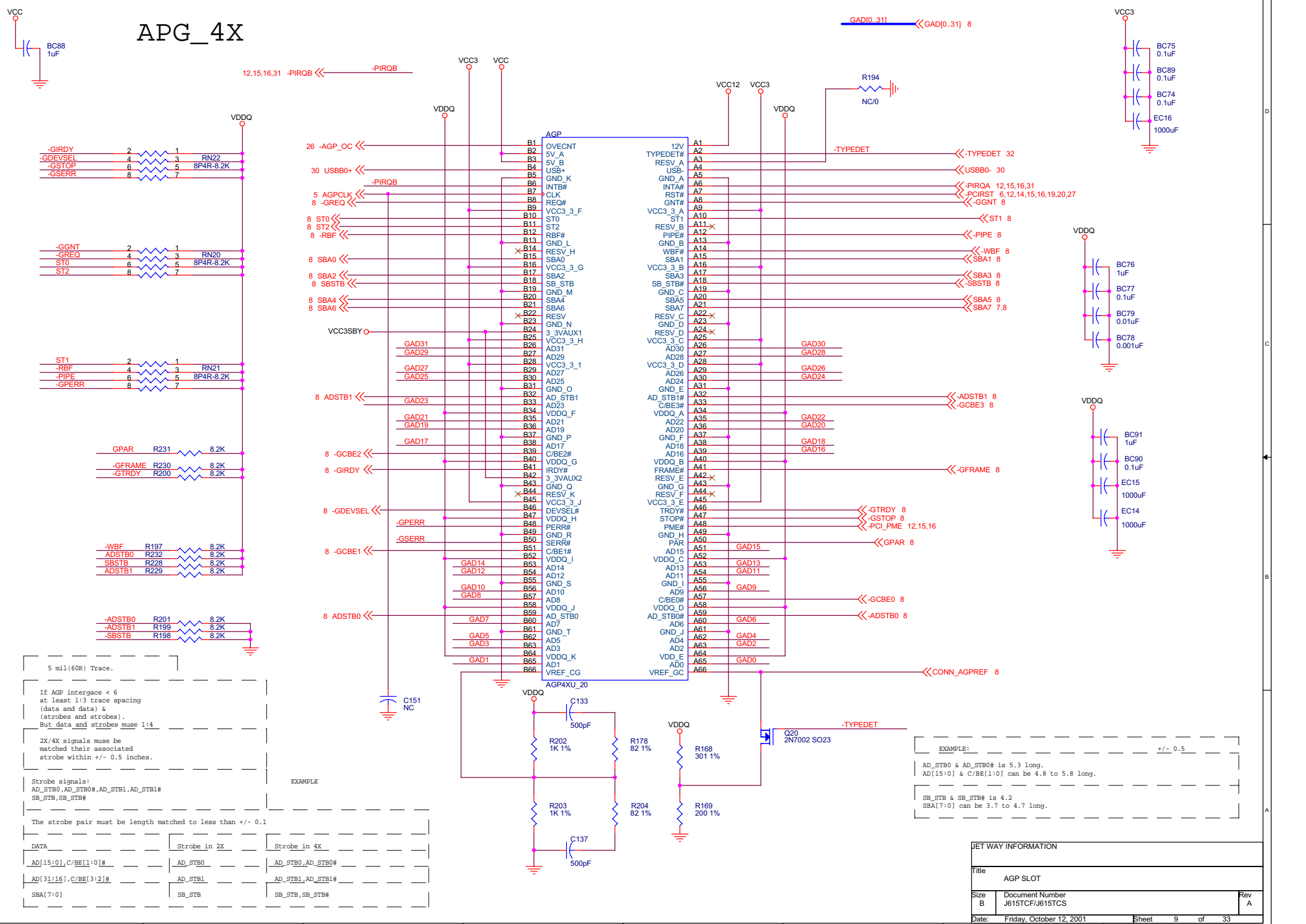

5 mil (60R) Trace.

If AGP intergrace < 6 at least 1:3 trace spacing (data and data) & (strokes and strokes). But data and strokes muse 1:4

2X/4X signals muse be matched their associated strobe within +/- 0.5 inches.

Strobe signals:  
AD\_STB0, AD\_STB0#, AD\_STB1, AD\_STB1#  
SB\_STB, SB\_STB#

The strobe pair must be length matched to less than +/- 0.1

DATA	Strobe in 2X	Strobe in 4X
AD[15:0], C/BE[1:0]#	AD_STB0	AD_STB0, AD_STB0#
AD[31:16], C/BE[3:2]#	AD_STB1	AD_STB1, AD_STB1#
SBA[7:0]	SB_STB	SB_STB, SB_STB#

EXAMPLE

EXAMPLE:

AD\_STB0 & AD\_STB0# is 5.3 long.  
AD[15:0] & C/BE[1:0] can be 4.8 to 5.8 long.

SB\_STB & SB\_STB# is 4.2  
SBA[7:0] can be 3.7 to 4.7 long.

JET WAY INFORMATION		
Title	AGP SLOT	
Size	Document Number	Rev
B	J615TCF/J615TCS	A
Date:	Friday, October 12, 2001	Sheet 9 of 33



RESERVED

JET WAY INFORMATION			
Title		RESERVED	
Size	Document Number	Rev	
B	J615TCF/J615TCS	A	
Date:	Friday, October 12, 2001	Sheet	11 of 33

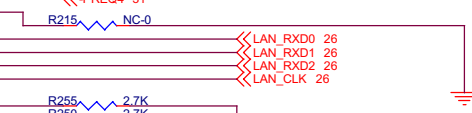
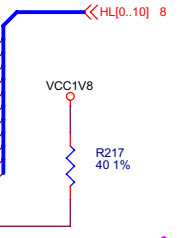
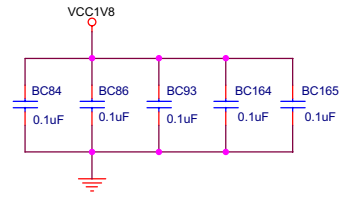
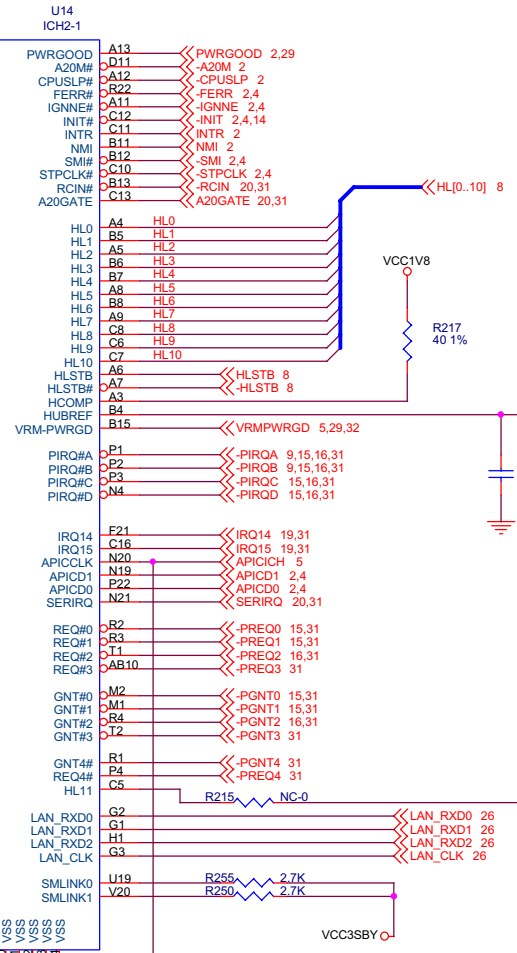
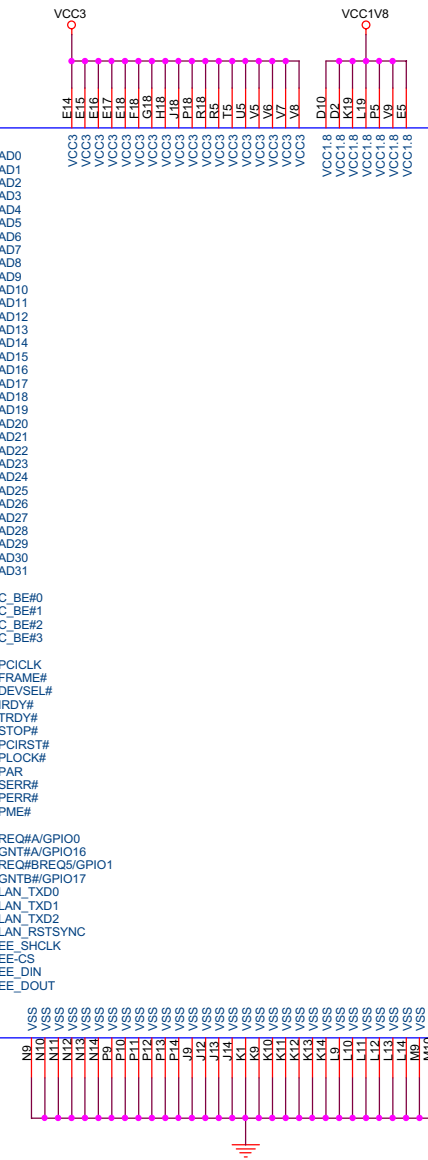
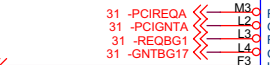
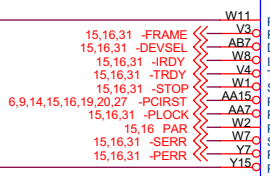
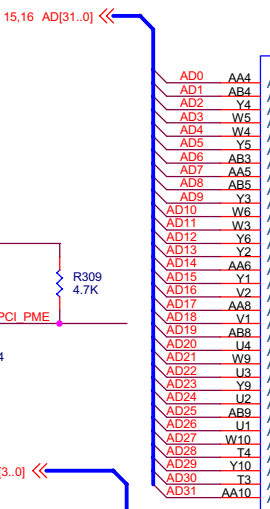
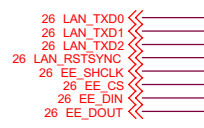
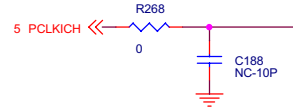
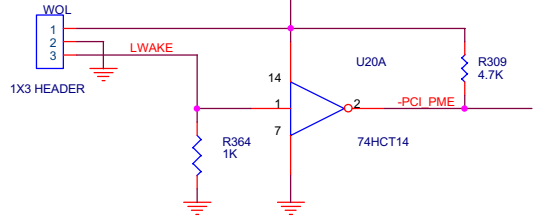
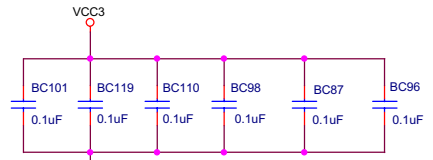

JET WAY INFORMATION			
Title ICH2,PART1			
Size B	Document Number J615TCF/J615TCS	Rev A	
Date: Friday, October 12, 2001	Sheet 12	of 33	

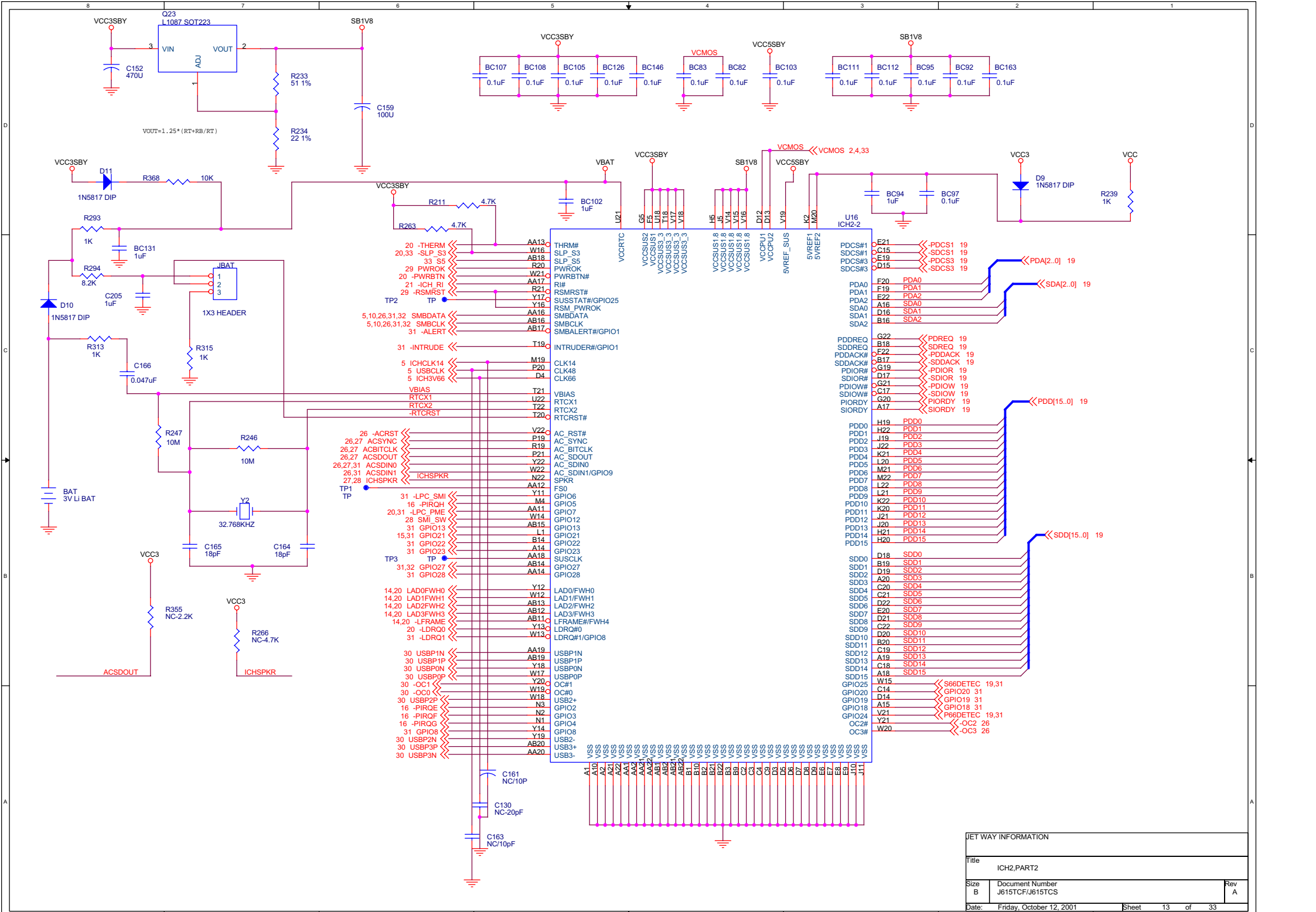

20 -THERM	THRM#	AA13	THRM#	AA13
20,33 -SLP_S3	SLP_S3	W16	SLP_S3	W16
33 -S3	SLP_S5	AB18	SLP_S5	AB18
29 -PWROK	PWR#OK	R20	PWR#OK	R20
20 -PWRBTN	PWRBTN#	W21	PWRBTN#	W21
21 -ICH_RI	RI#	AA17	RI#	AA17
29 -RSMRST	RSMRST#	R21	RSMRST#	R21
TP2	SUSSTAT#/GPIO25	Y17	SUSSTAT#/GPIO25	Y17
TP	RSM_PWROK	Y12	RSM_PWROK	Y12
5,10,26,31,32 -SMBDATA	SMBDATA	Y16	SMBDATA	Y16
5,10,26,31,32 -SMBCLK	SMBCLK	AA16	SMBCLK	AA16
31 -ALERT	SMBALERT#/GPIO1	AB16	SMBALERT#/GPIO1	AB16
31 -INTRUDE	INTRUDER#/GPIO1	AB17	INTRUDER#/GPIO1	AB17
TP1	T19	T19	T19	T19
5 ICHCLK14	CLK14	M19	CLK14	M19
5 USBCLK	CLK48	P20	CLK48	P20
5 ICH3V66	CLK66	D4	CLK66	D4
VBIA	VBIA	T21	VBIA	T21
RTCX1	RTCX1	U22	RTCX1	U22
RTCX2	RTCX2	T22	RTCX2	T22
-RTCRST	RTCRST#	T20	RTCRST#	T20
26 -ACRST	AC_RST#	V22	AC_RST#	V22
26,27 ACSYNC	AC_SYNC	P19	AC_SYNC	P19
26,27 ACBITCLK	AC_BITCLK	R19	AC_BITCLK	R19
26,27 ACSDOOUT	AC_SDOOUT	P21	AC_SDOOUT	P21
26,27,31 ACSDINO	AC_SDOIN0	Y22	AC_SDOIN0	Y22
26,31 ACSDIN1	AC_SGIN1/GPIO9	W22	AC_SGIN1/GPIO9	W22
27,28 ICHSPKR	SPKR	N22	SPKR	N22
TP3	FS0	AA12	FS0	AA12
31 -LPC_SMI	GPIO6	Y11	GPIO6	Y11
16 -PIRQH	GPIO5	M4	GPIO5	M4
20,31 -LPC_PME	GPIO7	AA11	GPIO7	AA11
28 SMI_SW	GPIO12	W14	GPIO12	W14
31 GPIO13	GPIO13	AB15	GPIO13	AB15
15,31 GPIO21	GPIO21	L1	GPIO21	L1
31 GPIO22	GPIO22	B14	GPIO22	B14
31 GPIO23	GPIO23	A14	GPIO23	A14
31 GPIO28	GPIO28	AA18	GPIO28	AA18
TP	SUSCLK	AB14	SUSCLK	AB14
31,32 GPIO27	GPIO27	AA14	GPIO27	AA14
31 GPIO28	GPIO28	AA14	GPIO28	AA14
14,20 LAD0FWH0	LAD0/FWH0	Y12	LAD0/FWH0	Y12
14,20 LAD1FWH1	LAD1/FWH1	W12	LAD1/FWH1	W12
14,20 LAD2FWH2	LAD2/FWH2	AB13	LAD2/FWH2	AB13
14,20 LAD3FWH3	LAD3/FWH3	AB12	LAD3/FWH3	AB12
14,20 -LFRAME	LFRAME#/FWH4	AB11	LFRAME#/FWH4	AB11
20 -LDRQ0	LDRQ#0	Y13	LDRQ#0	Y13
31 -LDRQ1	LDRQ#1/GPIO8	W13	LDRQ#1/GPIO8	W13
30 USBP1N	USBP1N	AA19	USBP1N	AA19
30 USBP1P	USBP1P	AB19	USBP1P	AB19
30 USBP0N	USBP0N	Y18	USBP0N	Y18
30 USBP0P	USBP0P	W17	USBP0P	W17
30 -OC1	OC#1	Y20	OC#1	Y20
30 -OC0	OC#0	W19	OC#0	W19
30 USBP2P	USB2+	N3	USB2+	N3
16 -PIRQ	GPIO2	N2	GPIO2	N2
16 -PIRQF	GPIO3	N1	GPIO3	N1
16 -PIRQG	GPIO4	N1	GPIO4	N1
31 GPIO8	GPIO8	Y14	GPIO8	Y14
30 USBP2N	USB2-	Y19	USB2-	Y19
30 USBP3P	USB3+	AB20	USB3+	AB20
30 USBP3N	USB3-	AA20	USB3-	AA20
VSS	VSS	A1	VSS	A1
VSS	VSS	A0	VSS	A0
VSS	VSS	A21	VSS	A21
VSS	VSS	A22	VSS	A22
VSS	VSS	AA1	VSS	AA1
VSS	VSS	AA2	VSS	AA2
VSS	VSS	AA3	VSS	AA3
VSS	VSS	AA4	VSS	AA4
VSS	VSS	AA5	VSS	AA5
VSS	VSS	AA6	VSS	AA6
VSS	VSS	AA7	VSS	AA7
VSS	VSS	AA8	VSS	AA8
VSS	VSS	AA9	VSS	AA9
VSS	VSS	AA10	VSS	AA10
VSS	VSS	AA11	VSS	AA11
VSS	VSS	AA12	VSS	AA12
VSS	VSS	AA13	VSS	AA13
VSS	VSS	AA14	VSS	AA14
VSS	VSS	AA15	VSS	AA15
VSS	VSS	AA16	VSS	AA16
VSS	VSS	AA17	VSS	AA17
VSS	VSS	AA18	VSS	AA18
VSS	VSS	AA19	VSS	AA19
VSS	VSS	AA20	VSS	AA20
VSS	VSS	AA21	VSS	AA21
VSS	VSS	AA22	VSS	AA22
VSS	VSS	AA23	VSS	AA23
VSS	VSS	AA24	VSS	AA24
VSS	VSS	AA25	VSS	AA25
VSS	VSS	AA26	VSS	AA26
VSS	VSS	AA27	VSS	AA27
VSS	VSS	AA28	VSS	AA28
VSS	VSS	AA29	VSS	AA29
VSS	VSS	AA30	VSS	AA30
VSS	VSS	AA31	VSS	AA31
VSS	VSS	AA32	VSS	AA32
VSS	VSS	AA33	VSS	AA33
VSS	VSS	AA34	VSS	AA34
VSS	VSS	AA35	VSS	AA35
VSS	VSS	AA36	VSS	AA36
VSS	VSS	AA37	VSS	AA37
VSS	VSS	AA38	VSS	AA38
VSS	VSS	AA39	VSS	AA39
VSS	VSS	AA40	VSS	AA40
VSS	VSS	AA41	VSS	AA41
VSS	VSS	AA42	VSS	AA42
VSS	VSS	AA43	VSS	AA43
VSS	VSS	AA44	VSS	AA44
VSS	VSS	AA45	VSS	AA45
VSS	VSS	AA46	VSS	AA46
VSS	VSS	AA47	VSS	AA47
VSS	VSS	AA48	VSS	AA48
VSS	VSS	AA49	VSS	AA49
VSS	VSS	AA50	VSS	AA50
VSS	VSS	AA51	VSS	AA51
VSS	VSS	AA52	VSS	AA52
VSS	VSS	AA53	VSS	AA53
VSS	VSS	AA54	VSS	AA54
VSS	VSS	AA55	VSS	AA55
VSS	VSS	AA56	VSS	AA56
VSS	VSS	AA57	VSS	AA57
VSS	VSS	AA58	VSS	AA58
VSS	VSS	AA59	VSS	AA59
VSS	VSS	AA60	VSS	AA60
VSS	VSS	AA61	VSS	AA61
VSS	VSS	AA62	VSS	AA62
VSS	VSS	AA63	VSS	AA63
VSS	VSS	AA64	VSS	AA64
VSS	VSS	AA65	VSS	AA65
VSS	VSS	AA66	VSS	AA66
VSS	VSS	AA67	VSS	AA67
VSS	VSS	AA68	VSS	AA68
VSS	VSS	AA69	VSS	AA69
VSS	VSS	AA70	VSS	AA70
VSS	VSS	AA71	VSS	AA71
VSS	VSS	AA72	VSS	AA72
VSS	VSS	AA73	VSS	AA73
VSS	VSS	AA74	VSS	AA74
VSS	VSS	AA75	VSS	AA75
VSS	VSS	AA76	VSS	AA76
VSS	VSS	AA77	VSS	AA77
VSS	VSS	AA78	VSS	AA78
VSS	VSS	AA79	VSS	AA79
VSS	VSS	AA80	VSS	AA80
VSS	VSS	AA81	VSS	AA81
VSS	VSS	AA82	VSS	AA82
VSS	VSS	AA83	VSS	AA83
VSS	VSS	AA84	VSS	AA84
VSS	VSS	AA85	VSS	AA85
VSS	VSS	AA86	VSS	AA86
VSS	VSS	AA87	VSS	AA87
VSS	VSS	AA88	VSS	AA88
VSS	VSS	AA89	VSS	AA89
VSS	VSS	AA90	VSS	AA90
VSS	VSS	AA91	VSS	AA91
VSS	VSS	AA92	VSS	AA92
VSS	VSS	AA93	VSS	AA93
VSS	VSS	AA94	VSS	AA94
VSS	VSS	AA95	VSS	AA95
VSS	VSS	AA96	VSS	AA96
VSS	VSS	AA97	VSS	AA97
VSS	VSS	AA98	VSS	AA98
VSS	VSS	AA99	VSS	AA99
VSS	VSS	AA100	VSS	AA100
VSS	VSS	AA101	VSS	AA101
VSS	VSS	AA102	VSS	AA102
VSS	VSS	AA103	VSS	AA103
VSS	VSS	AA104	VSS	AA104
VSS	VSS	AA105	VSS	AA105
VSS	VSS	AA106	VSS	AA106
VSS	VSS	AA107	VSS	AA107
VSS	VSS	AA108	VSS	AA108
VSS	VSS	AA109	VSS	AA109
VSS	VSS	AA110	VSS	AA110
VSS	VSS	AA111	VSS	AA111
VSS	VSS	AA112	VSS	AA112
VSS	VSS	AA113	VSS	AA113
VSS	VSS	AA114	VSS	AA114
VSS	VSS	AA115	VSS	AA115
VSS	VSS	AA116	VSS	AA116
VSS	VSS	AA117	VSS	AA117
VSS	VSS	AA118	VSS	AA118
VSS	VSS	AA119	VSS	AA119
VSS	VSS	AA120	VSS	AA120
VSS	VSS	AA121	VSS	AA121
VSS	VSS	AA122	VSS	AA122
VSS	VSS	AA123	VSS	AA123
VSS	VSS	AA124	VSS	AA124
VSS	VSS	AA125	VSS	AA125
VSS	VSS	AA126	VSS	AA126
VSS	VSS	AA127	VSS	AA127
VSS	VSS	AA128	VSS	AA128
VSS	VSS	AA129	VSS	AA129
VSS	VSS	AA130	VSS	AA130
VSS	VSS	AA131	VSS	AA131
VSS	VSS	AA132	VSS	AA132
VSS	VSS	AA133	VSS	AA133
VSS	VSS	AA134	VSS	AA134
VSS	VSS	AA135	VSS	AA135
VSS	VSS	AA136	VSS	AA136
VSS	VSS	AA137	VSS	AA137
VSS	VSS	AA138	VSS	AA138
VSS	VSS	AA139	VSS	AA139
VSS	VSS	AA140	VSS	AA140
VSS	VSS	AA141	VSS	AA141
VSS	VSS	AA142	VSS	AA142
VSS	VSS	AA143	VSS	AA143
VSS	VSS	AA144	VSS	AA144
VSS	VSS	AA145	VSS	AA145
VSS	VSS	AA146	VSS	AA146
VSS	VSS	AA147	VSS	AA147
VSS	VSS	AA148	VSS	AA148
VSS	VSS	AA149	VSS	AA149
VSS	VSS	AA150	VSS	AA150
VSS	VSS	AA151	VSS	AA151
VSS	VSS	AA152	VSS	AA152
VSS	VSS	AA153	VSS	AA153
VSS	VSS	AA154	VSS	AA154
VSS	VSS	AA155	VSS	AA155
VSS	VSS	AA156	VSS	AA156
VSS	VSS	AA157	VSS	AA157
VSS	VSS	AA158	VSS	AA158
VSS	VSS	AA159	VSS	AA159
VSS	VSS	AA160	VSS	AA160
VSS	VSS	AA161	VSS	AA161
VSS	VSS	AA162	VSS	AA162
VSS	VSS	AA163	VSS	AA163
VSS	VSS	AA164	VSS	AA164
VSS	VSS	AA165	VSS	AA165
VSS	VSS	AA166	VSS	AA166
VSS	VSS	AA167	VSS	AA167
VSS	VSS	AA168	VSS	AA168
VSS	VSS	AA169	VSS	AA169
VSS	VSS	AA170	VSS	AA170
VSS	VSS	AA171	VSS	AA171
VSS	VSS	AA172	VSS	AA172
VSS	VSS	AA173	VSS	AA173
VSS	VSS	AA174	VSS	AA174
VSS	VSS	AA175	VSS	AA175</

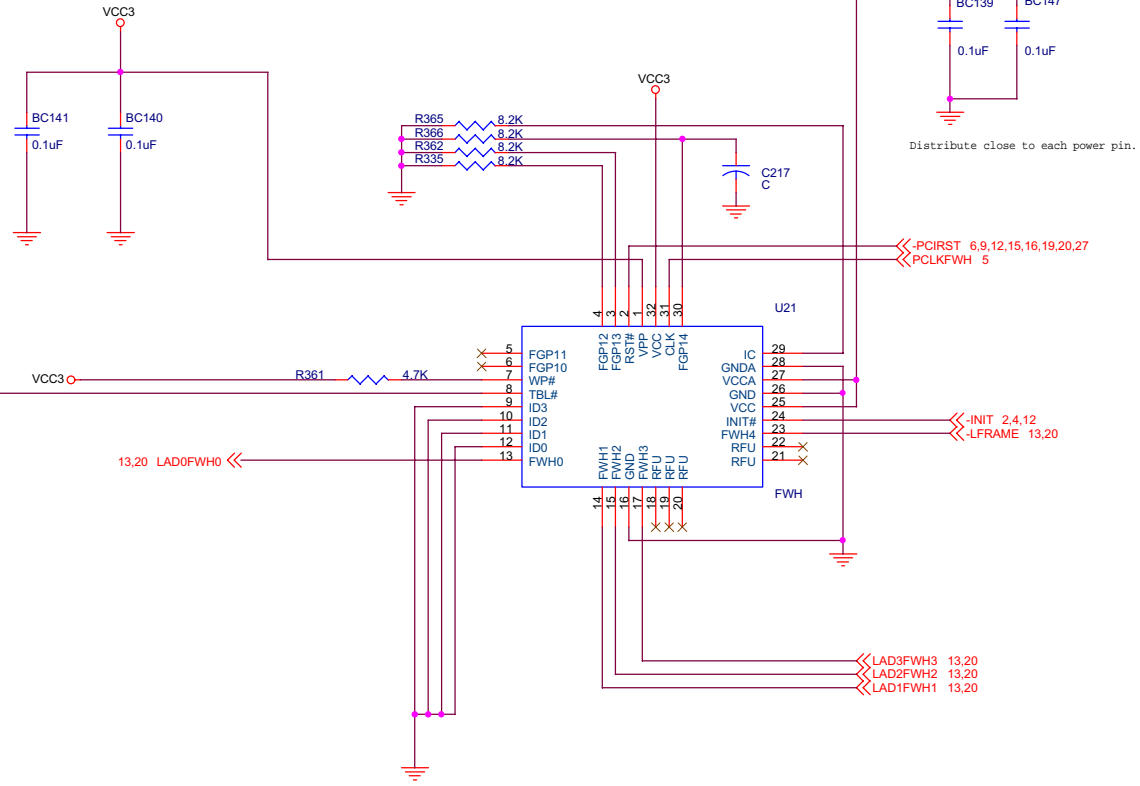
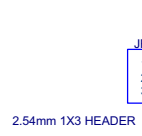
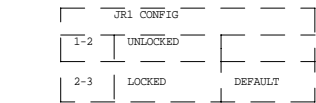

NOTES:

VPP and WP# are tied to VCC3 in this configuration Write Protection is register based with the exception of the Boot Block.

JET WAY INFORMATION		
Title	FIRMWARE HUB	
Size	Document Number	Rev
B	J615TCF/J615TCS	A
Date:	Friday, October 12, 2001	Sheet 14 of 33

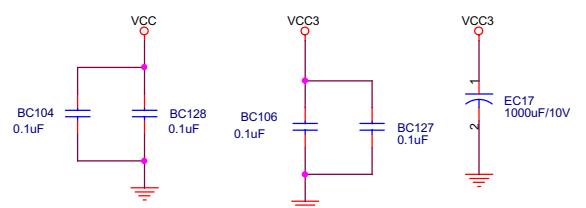
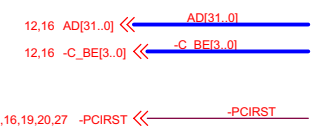
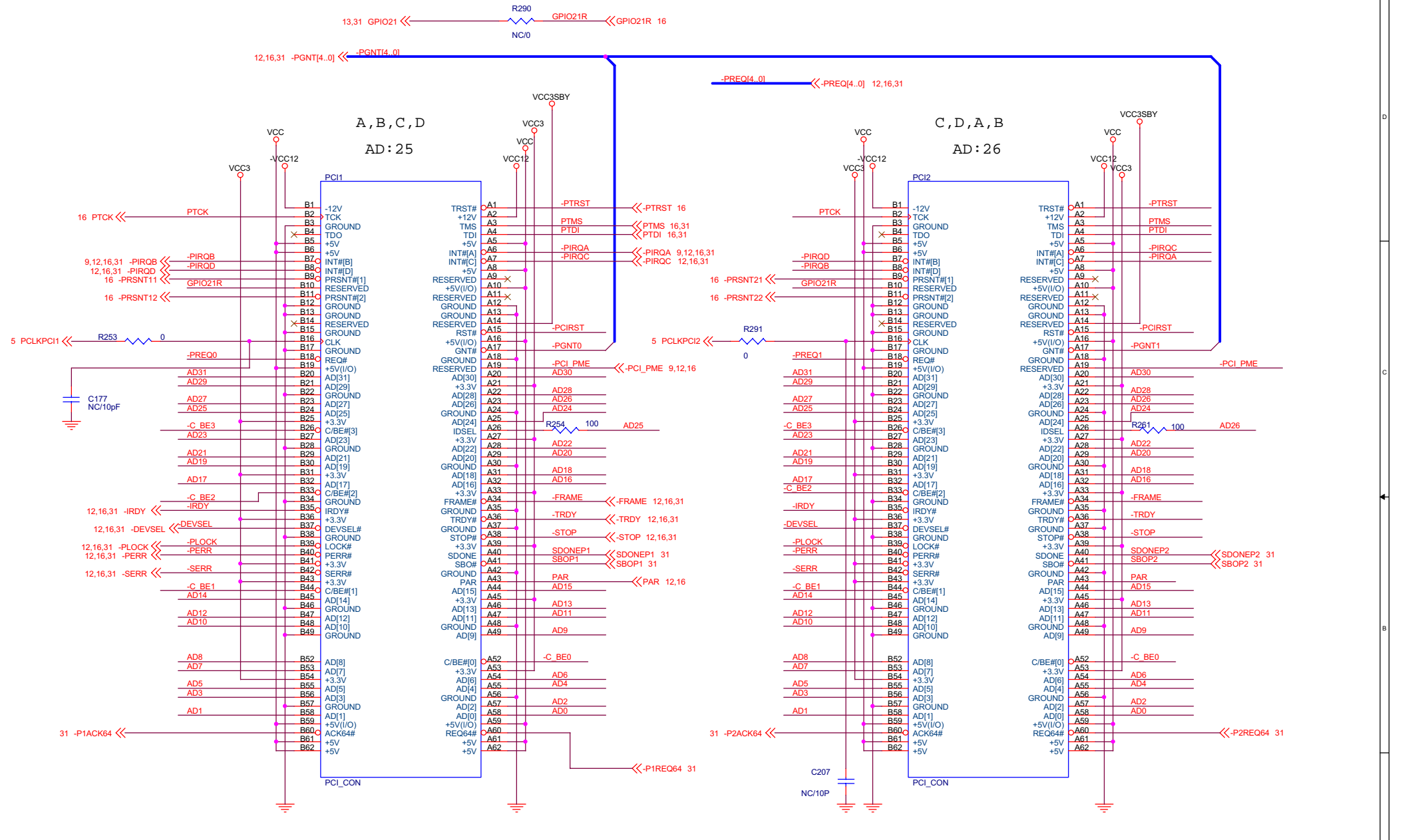

JET WAY INFORMATION		
Title PCI CONNECTOR 1 & 2		
Size B	Document Number J615TCF/J615TCS	Rev A
Date: Friday, October 12, 2001	Sheet 15	of 33

-PGNT[4..0] <<-PGNT[4..0] 12,15,31  
 -PREQ[4..0] <<-PREQ[4..0] 12,15,31

D, A, B, C  
 AD: 27

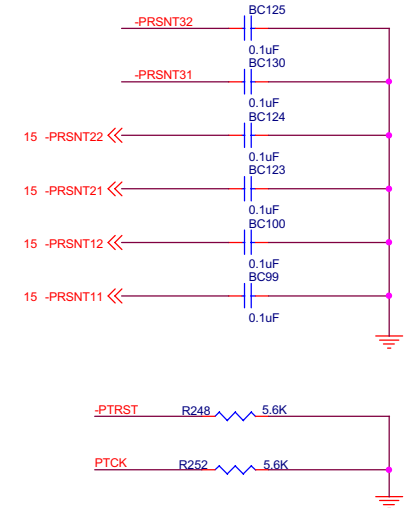
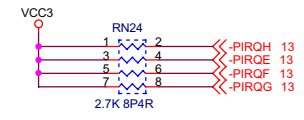
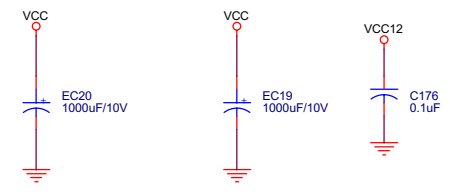
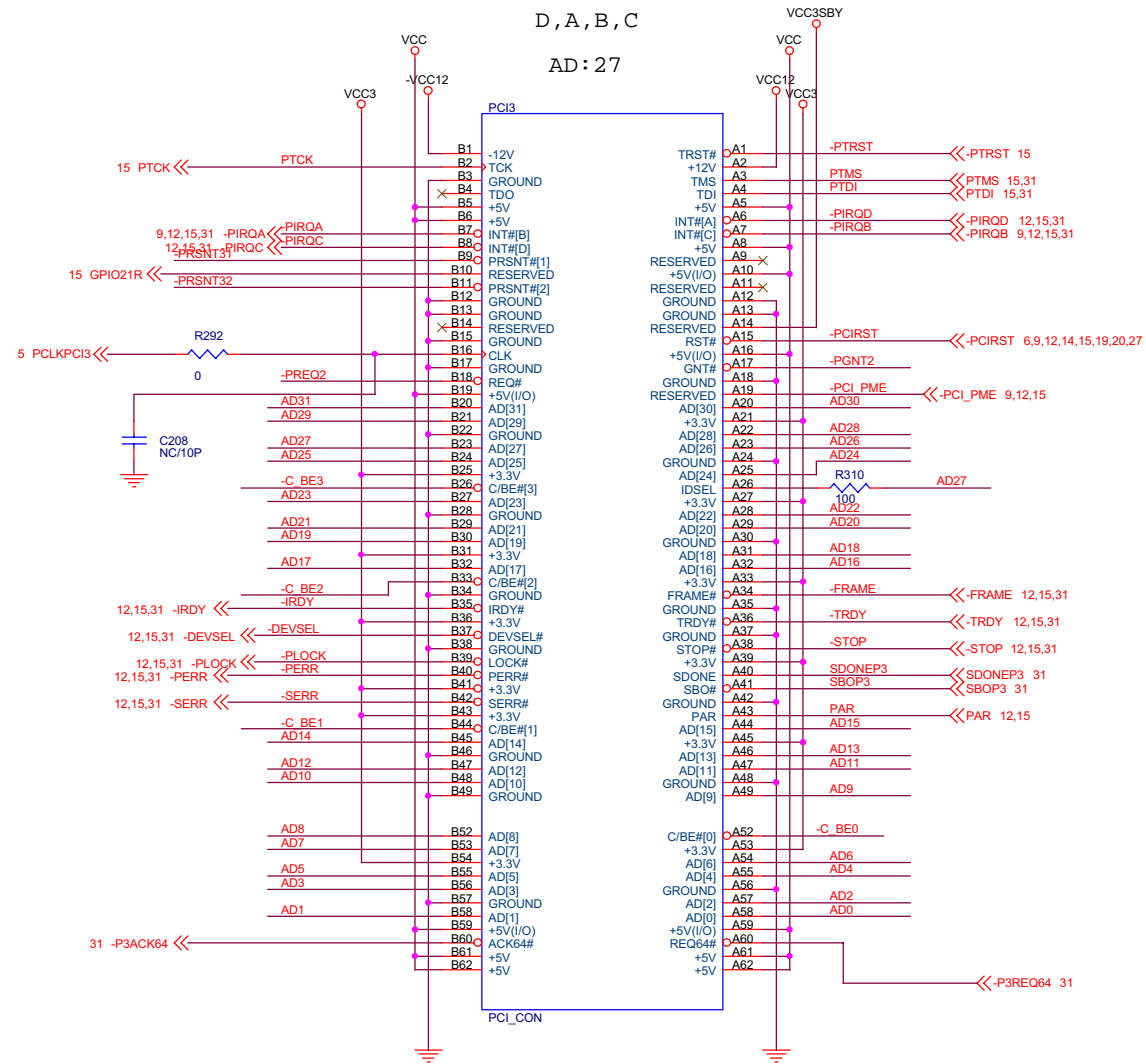

12,15 -C\_BE[3..0] <<-C\_BE[3..0]  
 12,15 AD[31..0] <<AD[31..0]

JET WAY INFORMATION		
Title PCI CONNECTOR 3		
Size B	Document Number J615TCF/J615TCS	Rev A
Date: Friday, October 12, 2001	Sheet 16	of 33

RESERVED

JET WAY INFORMATION			
Title		RESERVED	
Size	Document Number	Rev	
B	J615TCF/J615TCS	1	
Date:	Friday, October 12, 2001	Sheet	17 of 33

RESERVED

JET WAY INFORMATION			
Title		RESERVED	
Size	Document Number	Rev	
B	J615TCF/J615TCS	1	
Date:	Friday, October 12, 2001	Sheet	18 of 33

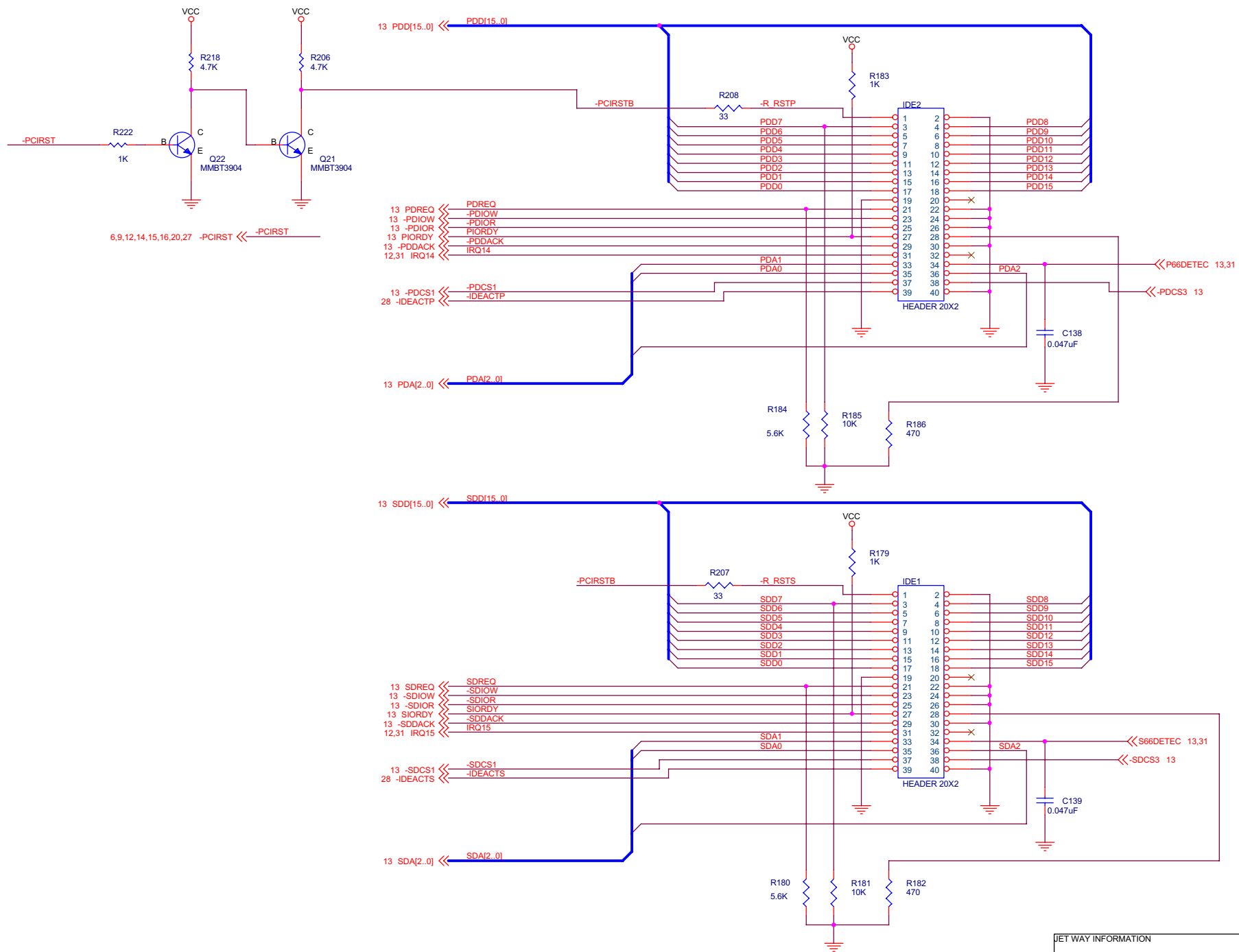

JET WAY INFORMATION		
Title IDE CONNECTORS		
Size B	Document Number J615TCF/J615TCS	Rev A
Date: Friday, October 12, 2001	Sheet 19	of 33



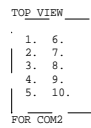
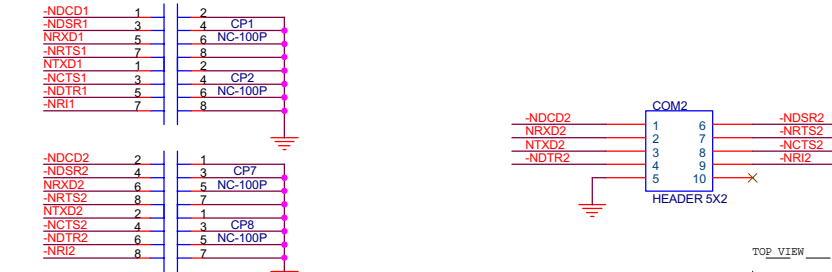
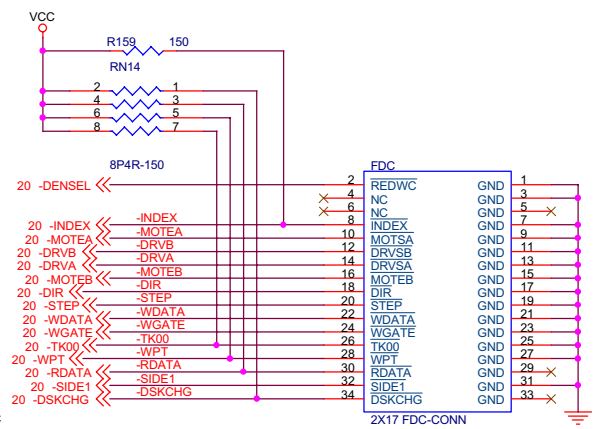
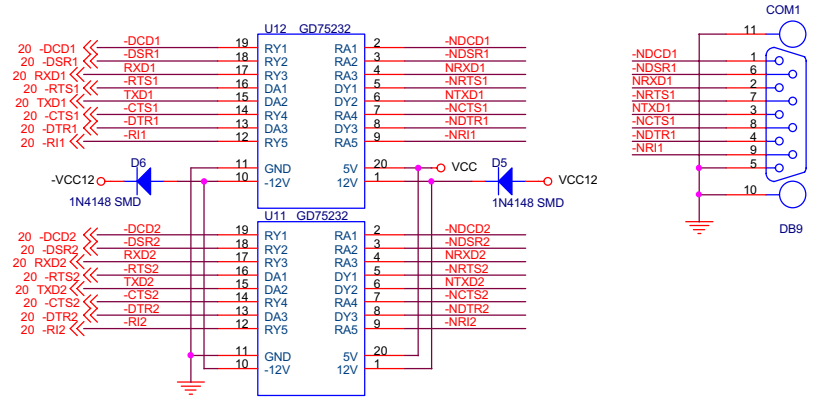
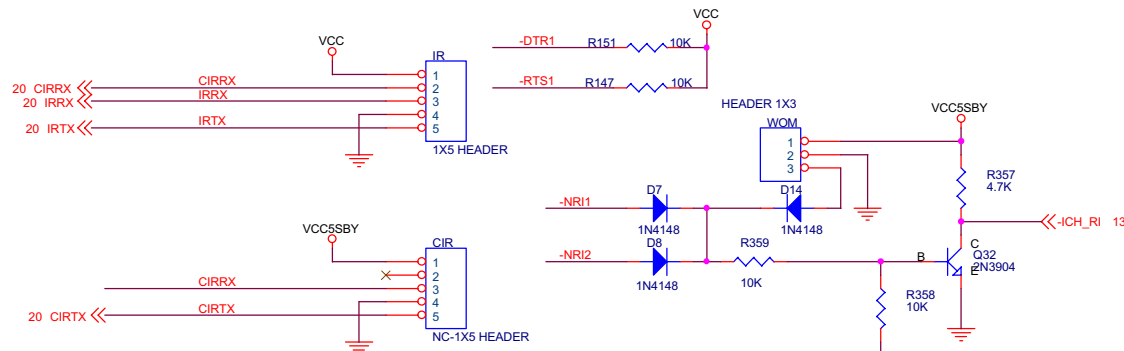

PRT PORT

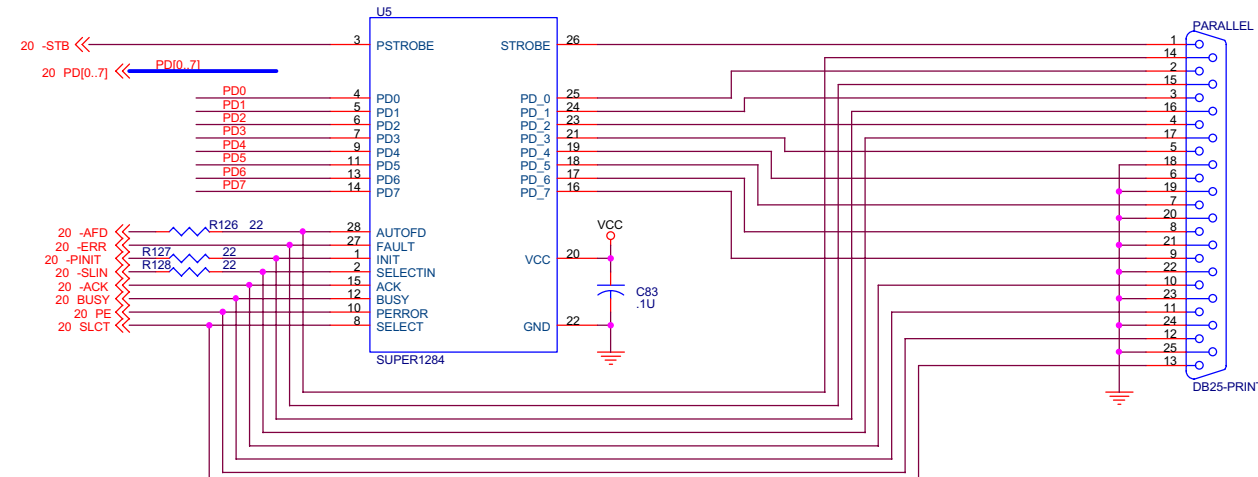

JET WAY INFORMATION		
Title	I/O CONNECTOR	
Size	Document Number	Rev
B	J615TCF/J615TCS	A
Date:	Friday, October 12, 2001	Sheet 21 of 33

# KBD & Mouse Connectors

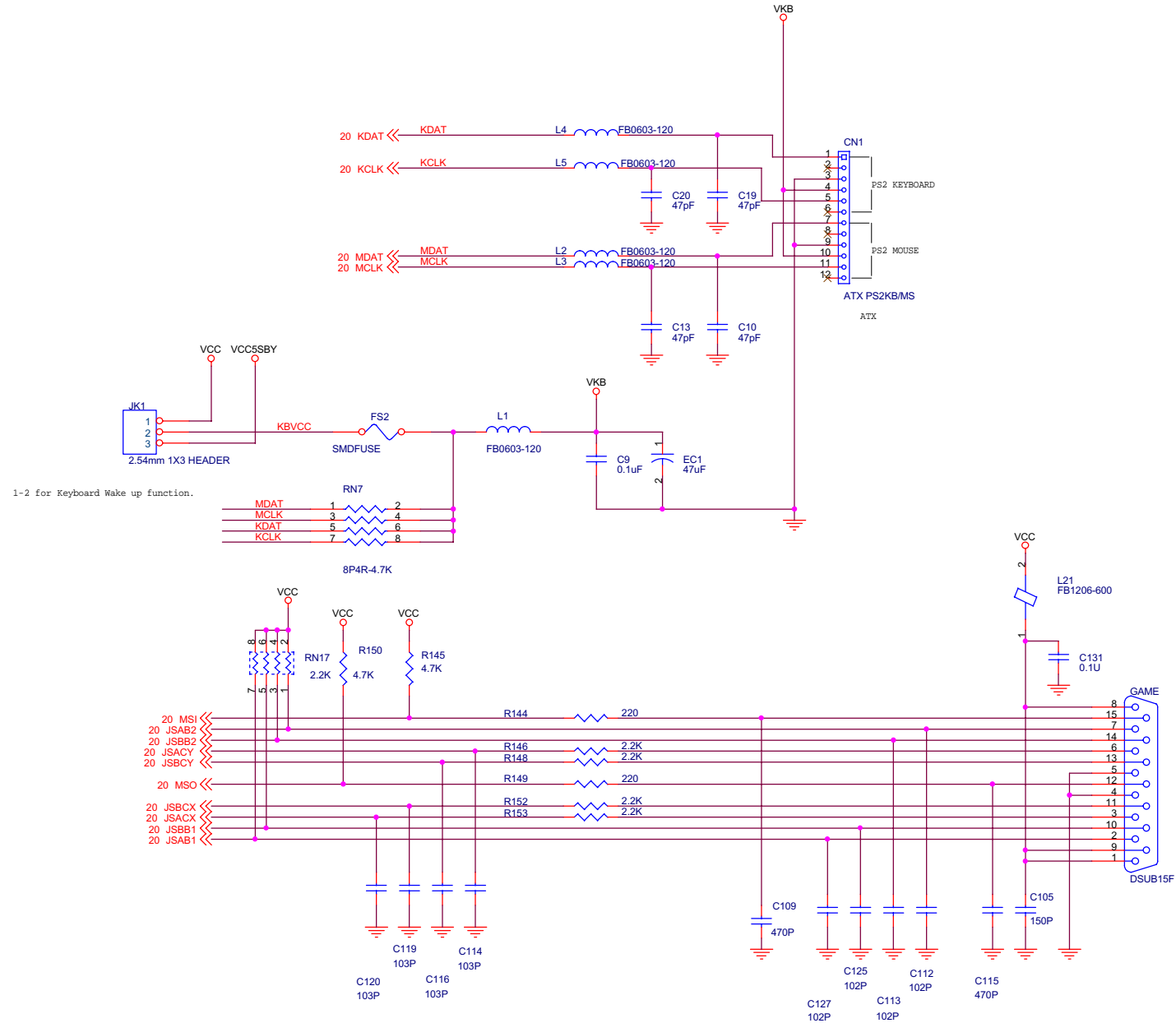
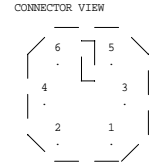
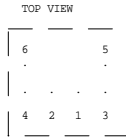

JET WAY INFORMATION		
Title	KBC, MOUSE, LPC, GAME	
Size	Document Number	Rev
B	J615TCF/J615TCS	A
Date:	Friday, October 12, 2001	Sheet 22 of 33

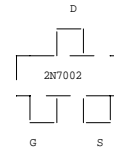

## FAN Input and Output

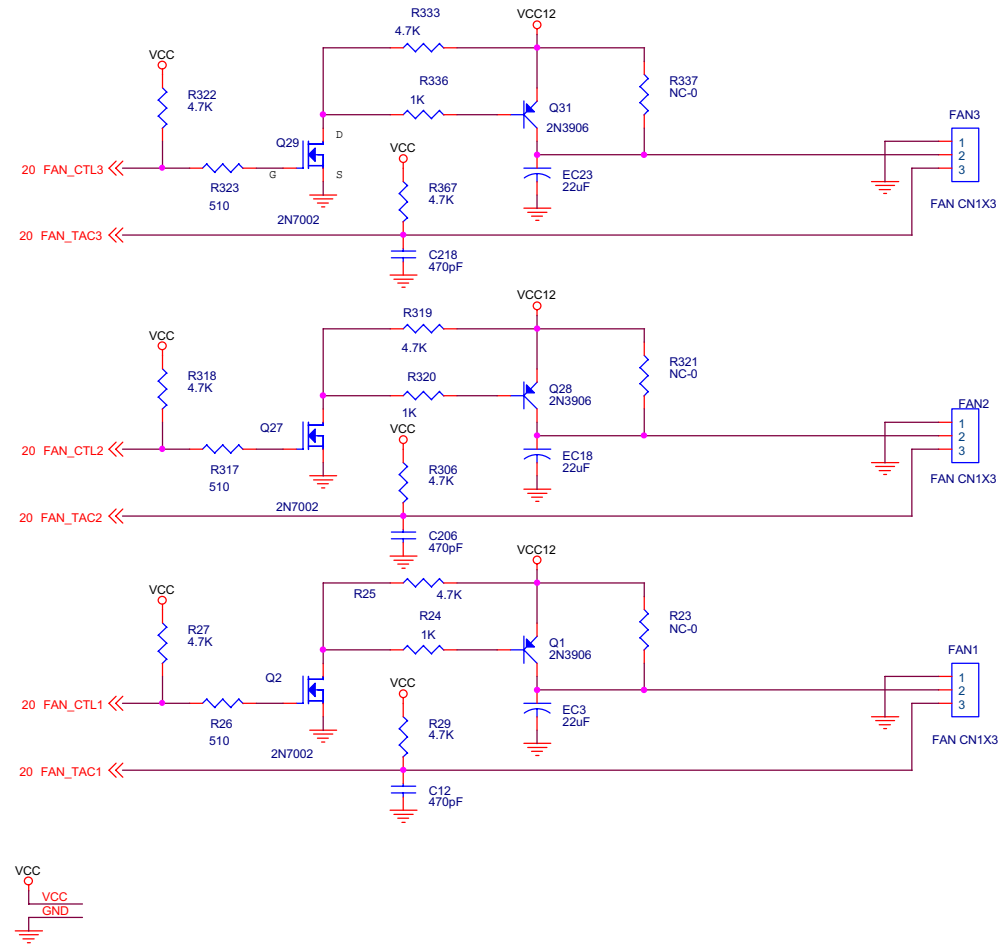

JET WAY INFORMATION		
Title	Game, MIDI Connector	
Size	Document Number	Rev
B	J615TCF/J615TCS	A
Date:	Friday, October 12, 2001	Sheet 23 of 33

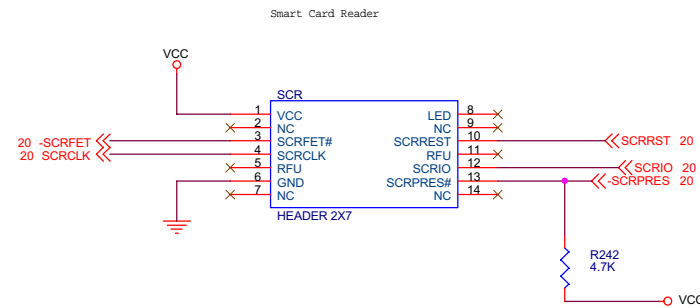
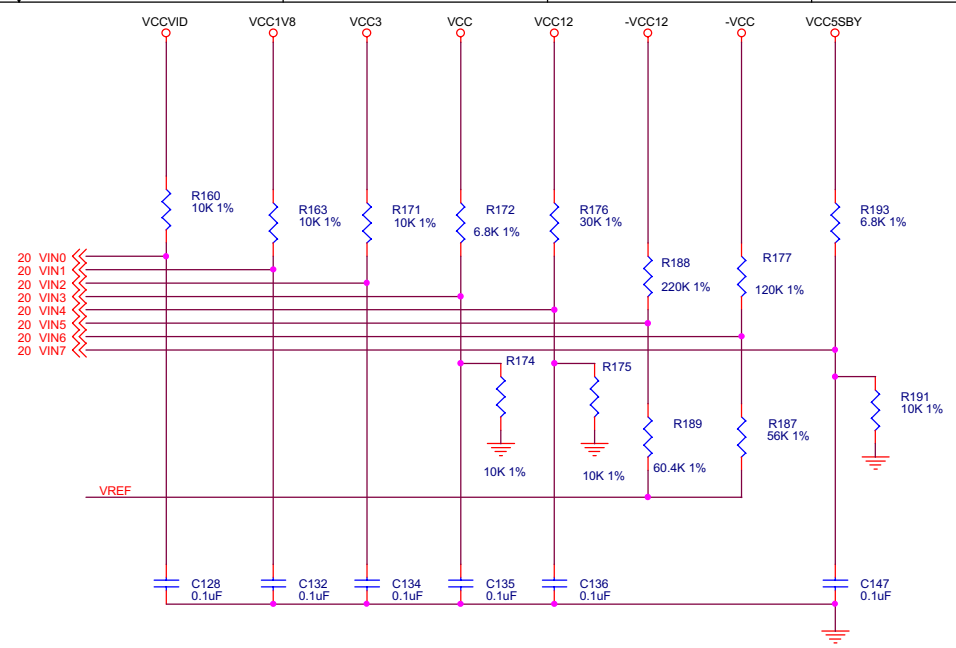
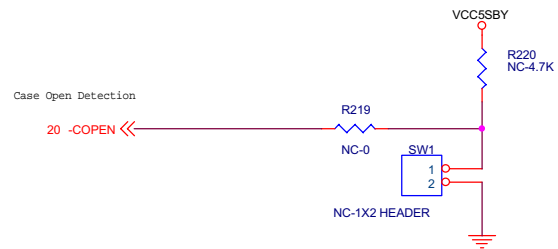
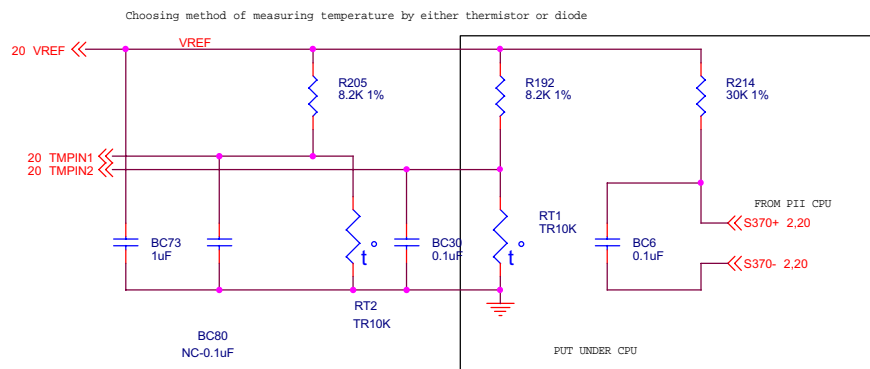

JET WAY INFORMATION		
Title	THERMISTOR, SMART CARD READER	
Size	Document Number	Rev
B	J615TCF/J615TCS	A
Date:	Friday, October 12, 2001	Sheet 24 of 33

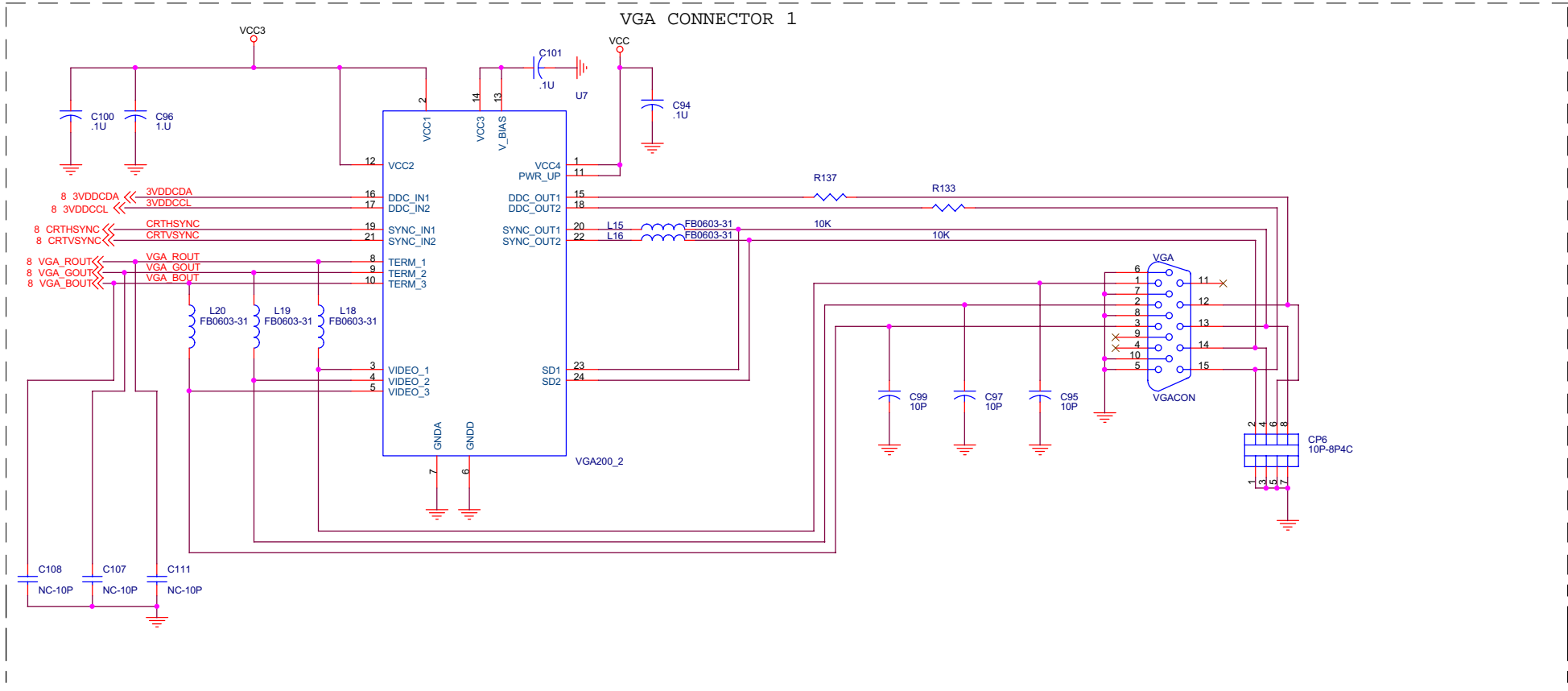

JET WAY INFORMATION		
Title VIDEO CONNECTORS		
Size B	Document Number J615TCF/J615TCS	Rev A
Date: Friday, October 12, 2001	Sheet 25	of 33

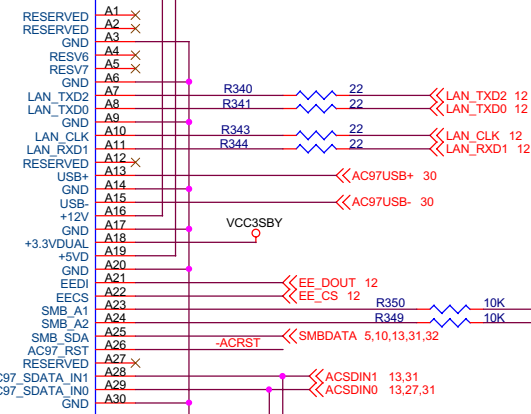
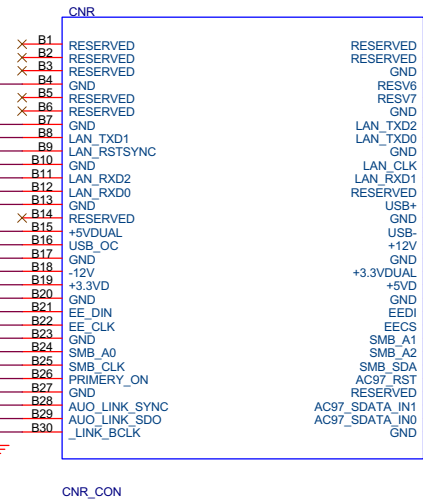
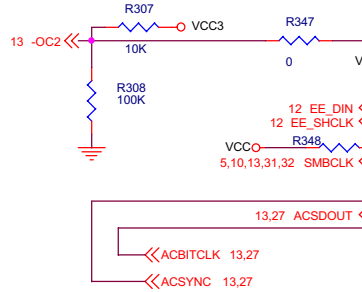
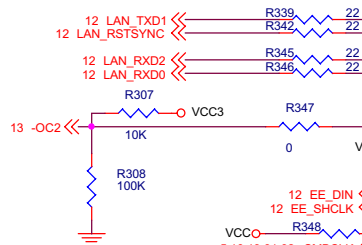
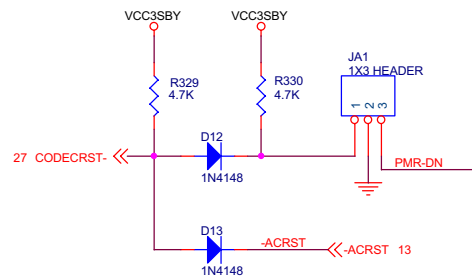
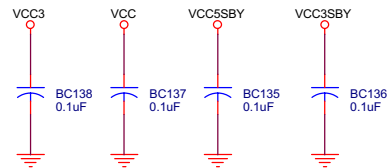
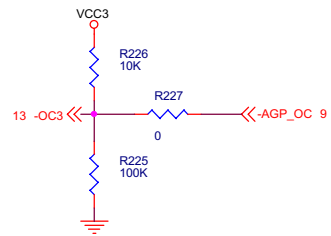

JET WAY INFORMATION			
Title CNR CONNECT			
Size B	Document Number J615TCF/J615TCS		Rev A
Date: Friday, October 12, 2001	Sheet 26	of 33	

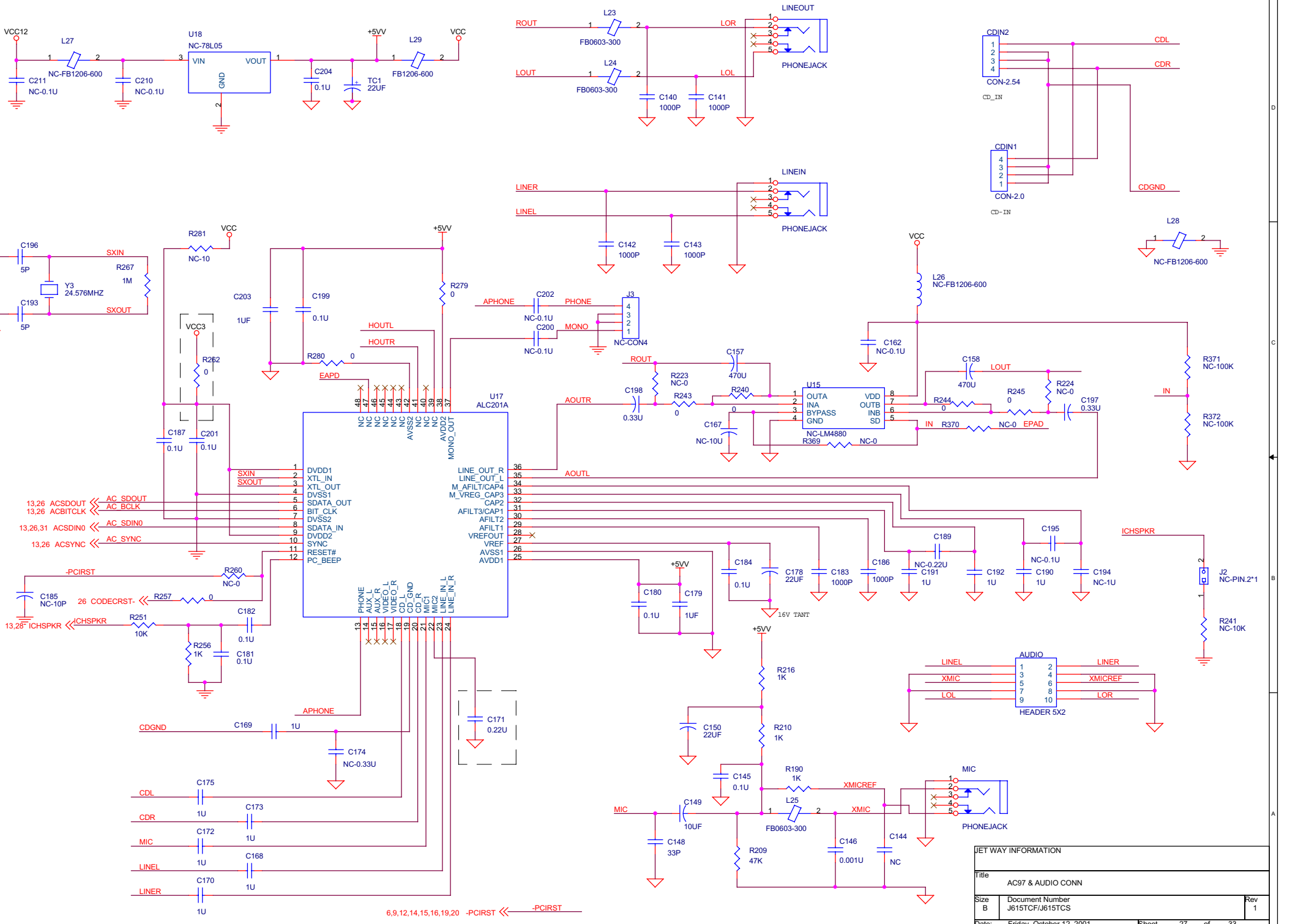

6,9,12,14,15,16,19,20 -PCIRST << -PCIRST

JET WAY INFORMATION		
Title AC97 & AUDIO CONN		
Size B	Document Number J615TCF/J615TCS	Rev 1
Date: Friday, October 12, 2001	Sheet 27	of 33

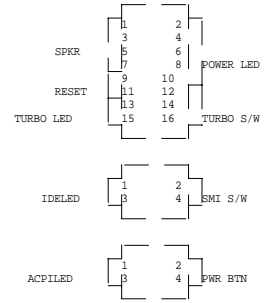
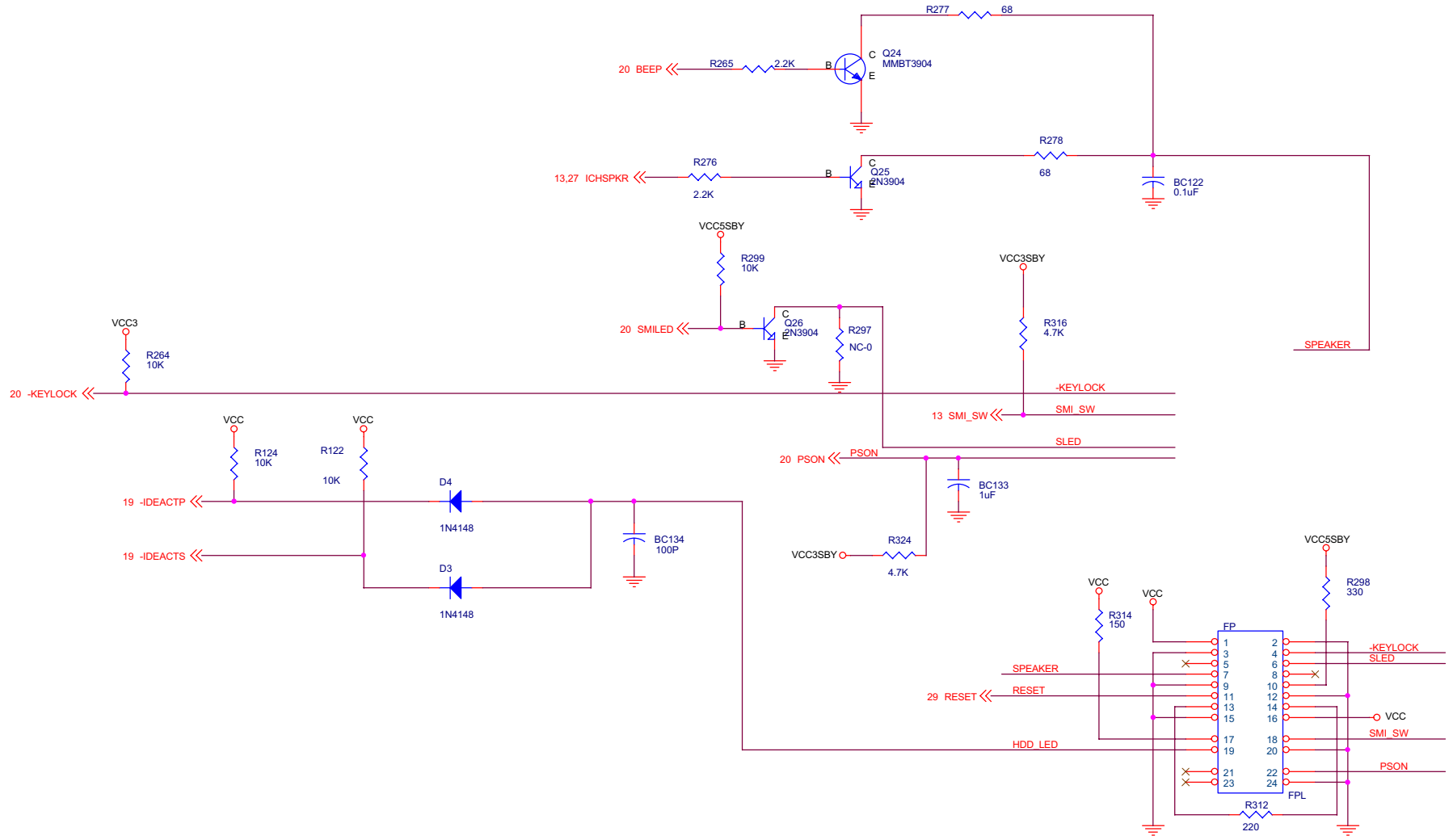

JET WAY INFORMATION		
Title	SYSTEM	
Size	Document Number	Rev
B	J615TCF/J615TCS	B
Date:	Friday, October 12, 2001	Sheet 28 of 33

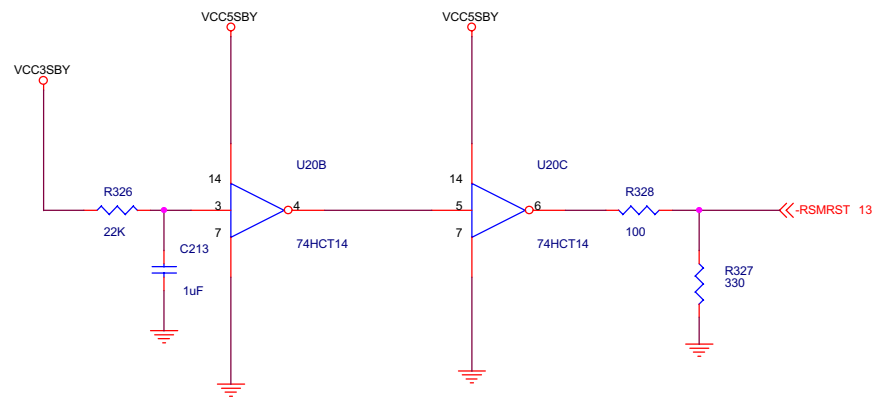
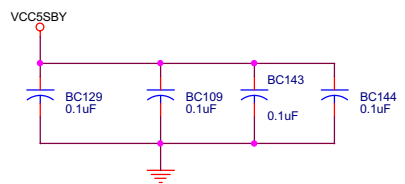
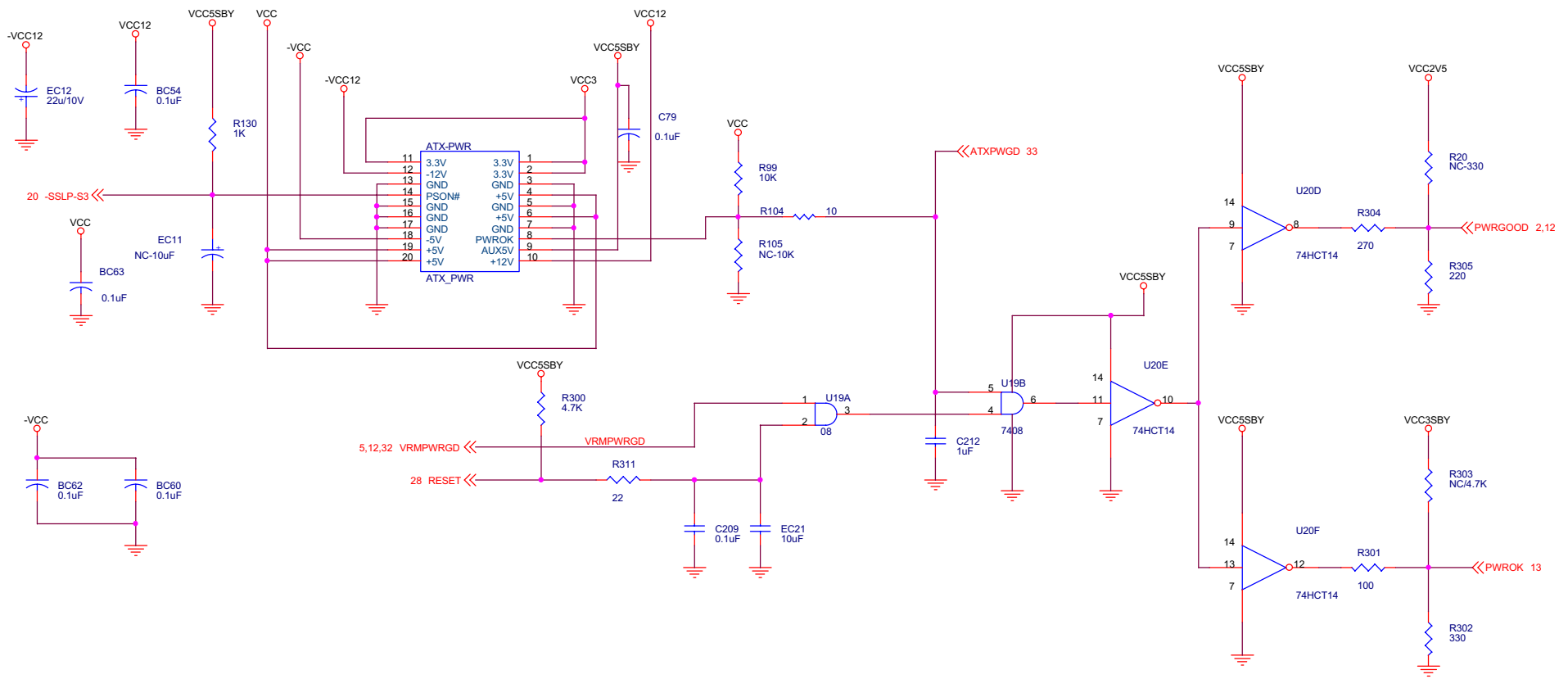

JET WAY INFORMATION		
Title System Power Connector and Reset Control		
Size B	Document Number J615TCF/J615TCS	Rev A
Date: Friday, October 12, 2001	Sheet 29	of 33

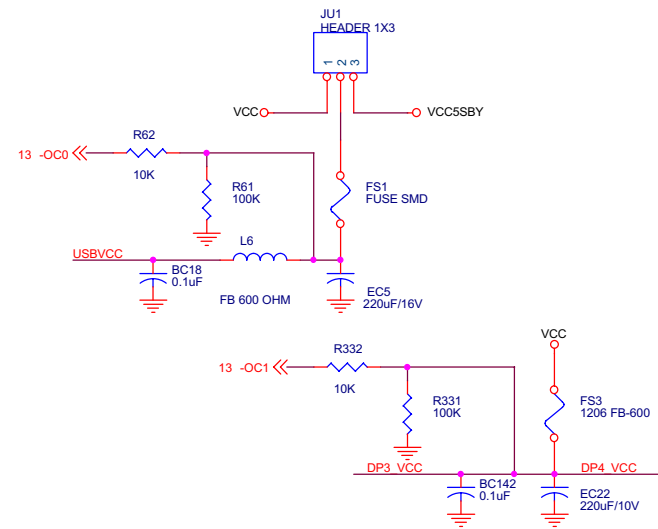
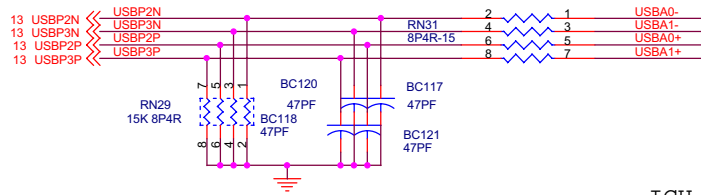

ICH

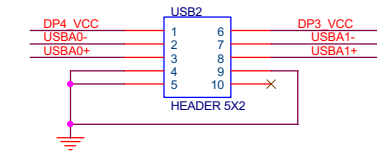
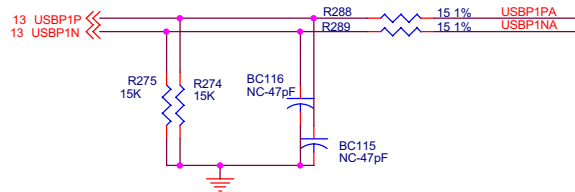

ICH

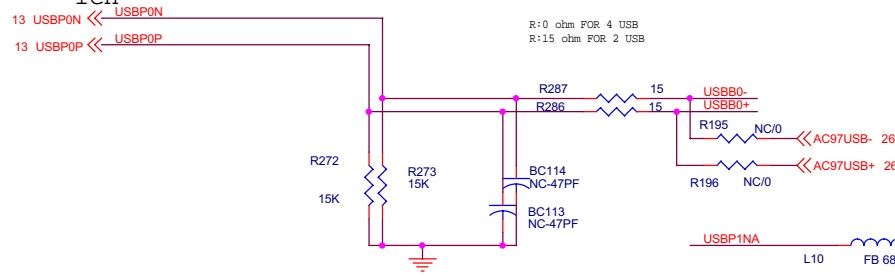

R:0 ohm FOR 4 USB  
 R:15 ohm FOR 2 USB

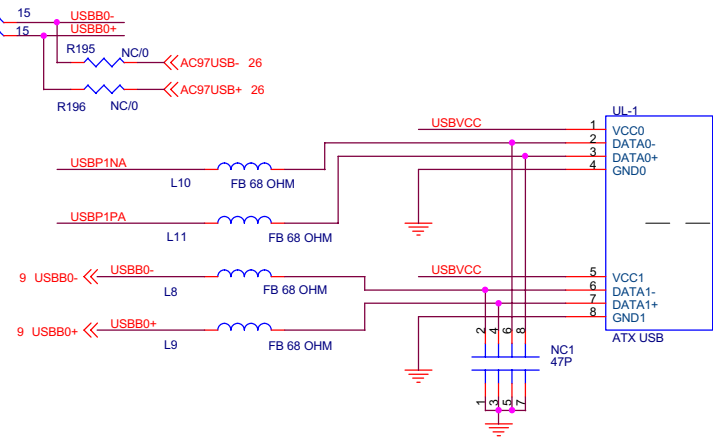

JET WAY INFORMATION		
Title USB CONNECTOR		
Size B	Document Number J615TCF/J615TCS	Rev A
Date: Friday, October 12, 2001	Sheet 30	of 33

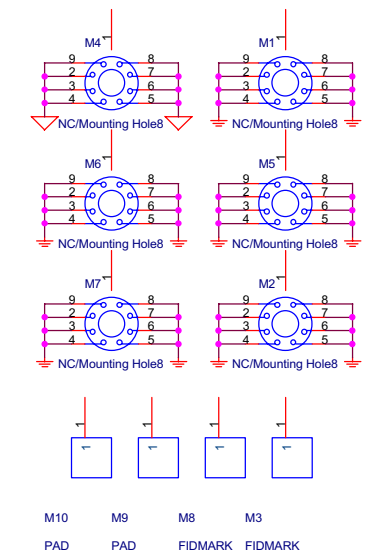
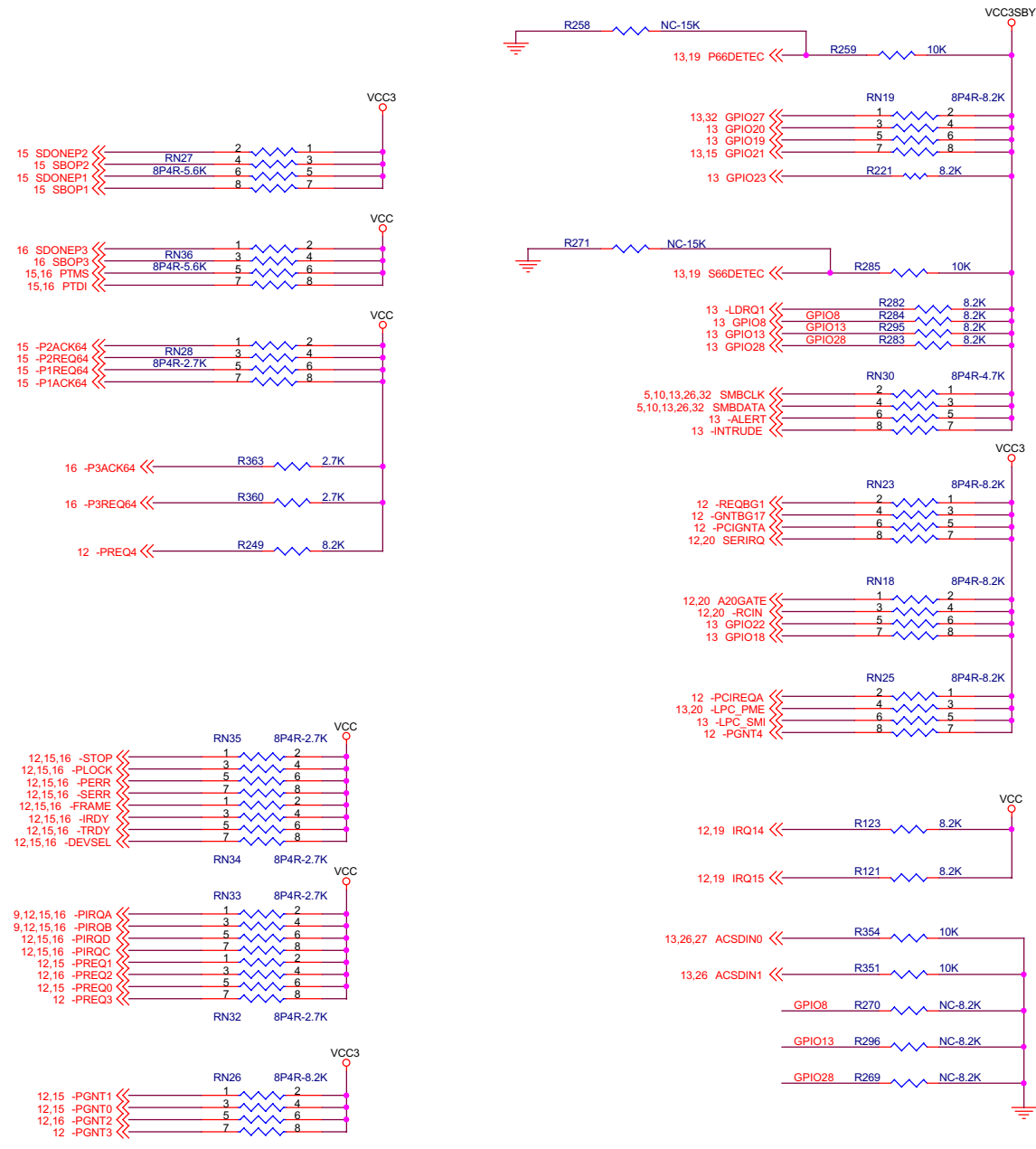

JET WAY INFORMATION			
Title	PULL-UP RESISTORS		
Size	Document Number		Rev
B	J615TCF/J615TCS		A
Date:	Friday, October 12, 2001	Sheet	31 of 33

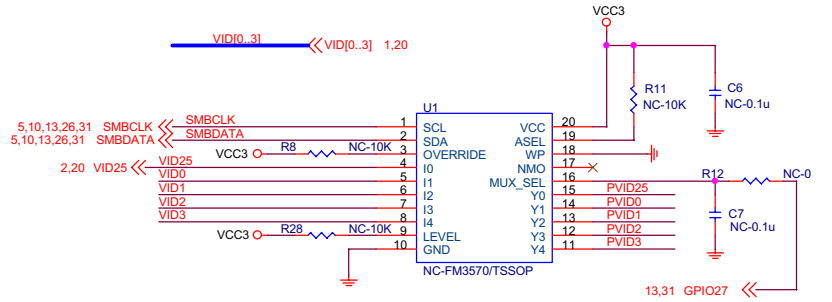
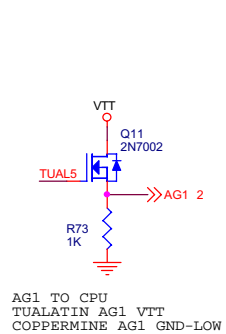
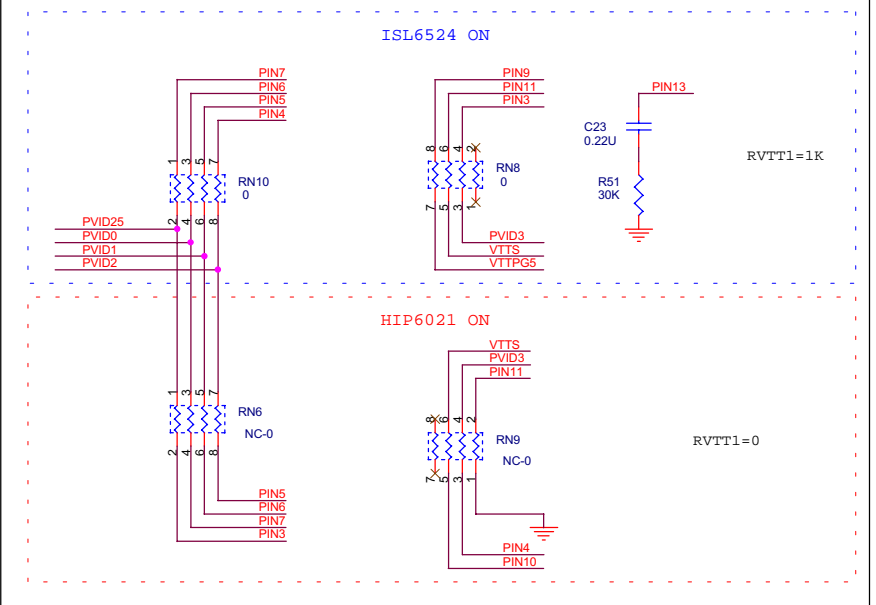
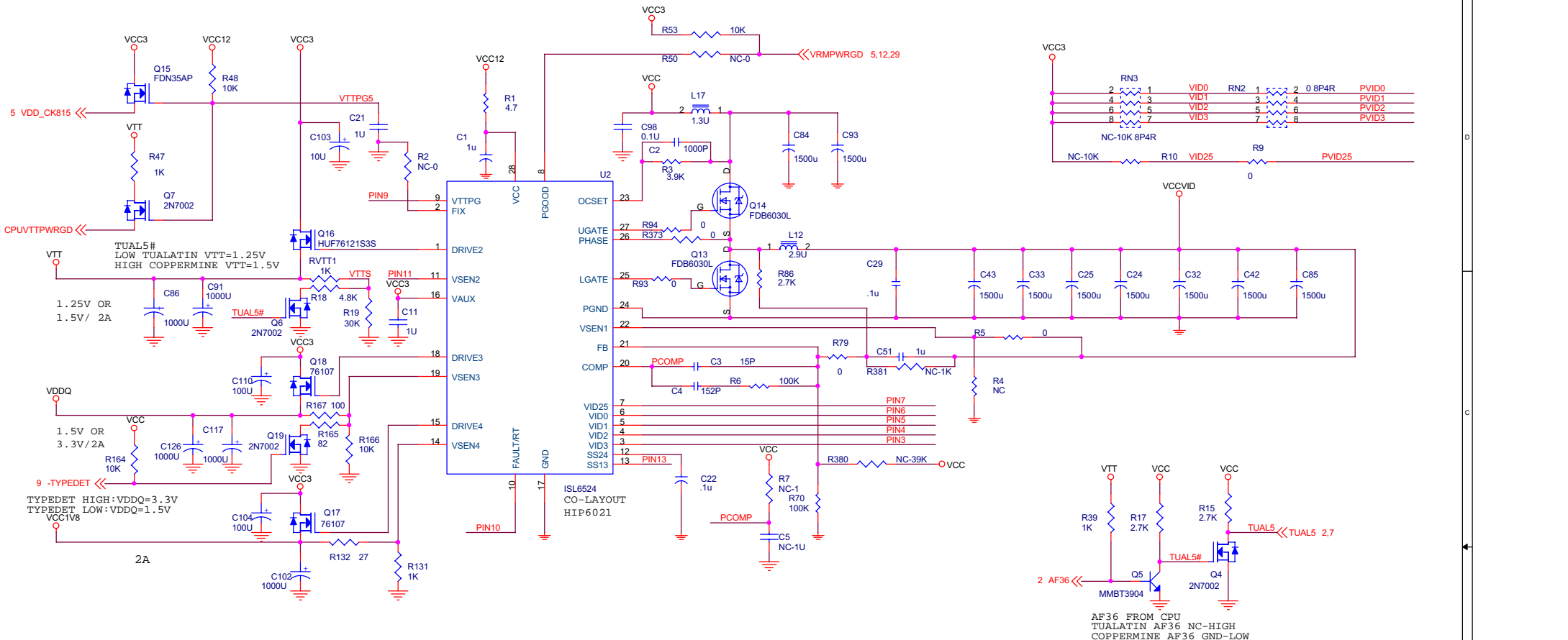

JETWAY INFORMATION			
Title DC-DC CONVERTER			
Size C	Document Number J615TCF/J615TCS		Rev 0.1
Date: Friday, October 12, 2001	Sheet 32	of 33	

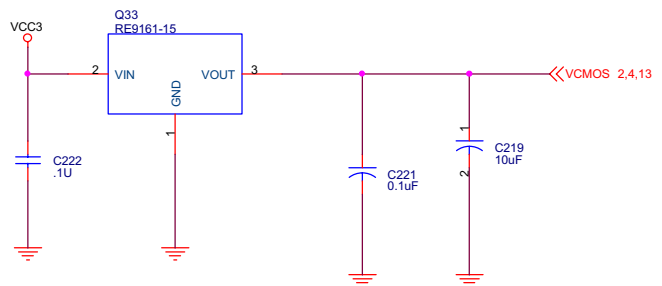
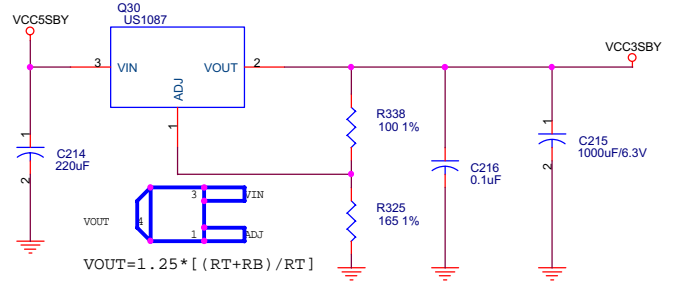
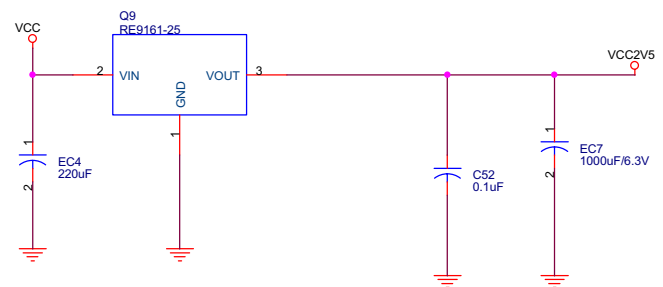
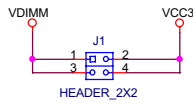
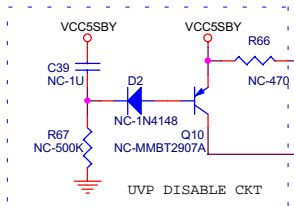
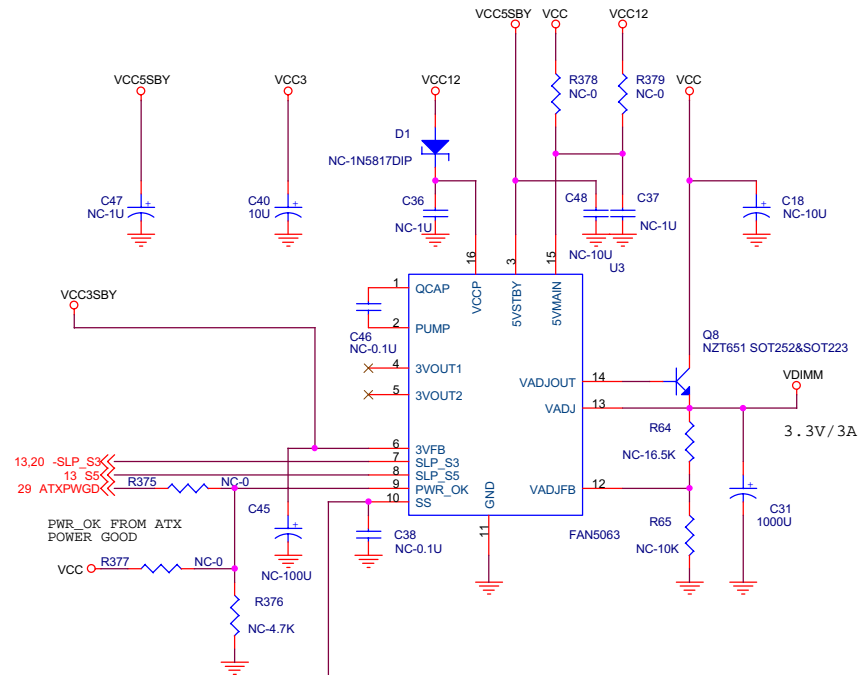

JETWAY INFORMATION			
Title DC-DC CONVERTER			
Size	Document Number J615TCF/J615TCS	Rev	0.1
Date:	Friday, October 12, 2001	Sheet	33 of 33