

JET WAY INFORMATION

MODEL: J-694AS

(SOCKET 370+VT82C694X+VT82C686B+AGP 4X+1 AMR)

TITLE	SHEET
COVER SHEET	1
SOCKET 370 PROCESSOR	2
NORTH BRIDGE (VT82C694X)	3, 4
SOUTH BRIDGE (VT82C686B)	5, 6
USB2,3 & FREQUENCY RATIO	7
SDRAM	8, 9
PCI SLOTS	10, 11, 12
AGP SLOT	13
ISA PULL UP RESISTANCE	14
IDE & PANEL	15
CLOCK SYNTHESIZER	16
BYPASS CAPACITORS	17
DC-DC CONVERTER	18
PRINTER / COM PORT	17
AUDIO CODEC & AUDIO PORT & JOSTICK PORT	20
AMR SLOT	21
ATX POWER CONNECTOR / VTT TERMINATOR / VCC3	22

- LINK
- 2.SCH
- 3.SCH
- 4.SCH
- 5.SCH
- 6.SCH
- 7.SCH
- 8.SCH
- 9.SCH
- 10.SCH
- 11.SCH
- 12.SCH
- 13.SCH
- 14.SCH
- 15.SCH
- 16.SCH
- 17.SCH
- 18.SCH
- 19.SCH
- 20.SCH
- 21.SCH
- 22.SCH

JETWAY INFORMATION			
Title			
COVER SHEET			
Size	Document Number	Rev	
	J-694AS	0.1	
Date:	Thursday, November 23, 2000	Sheet	1 of 22

SOCKET 370

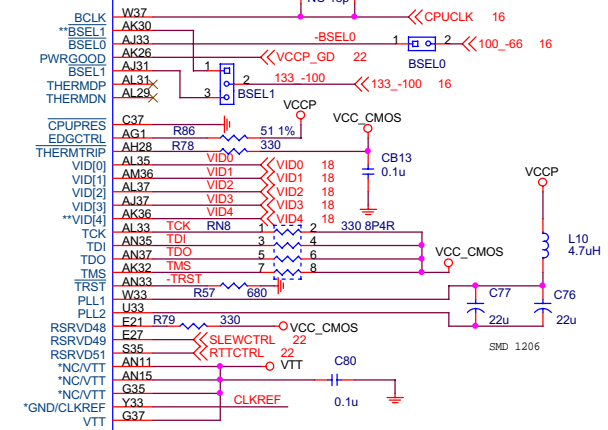
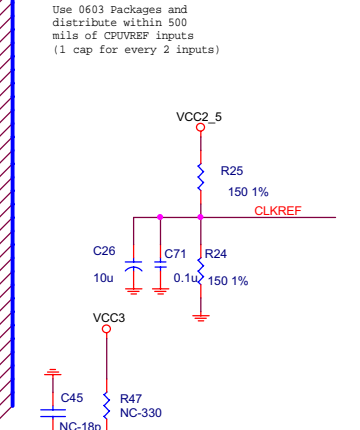
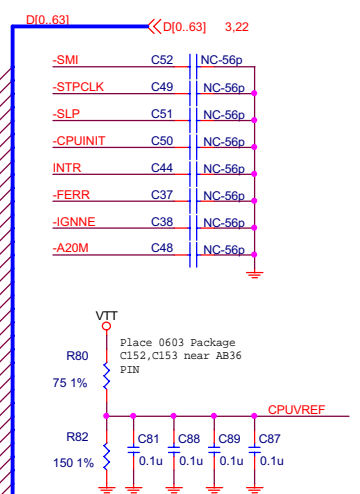
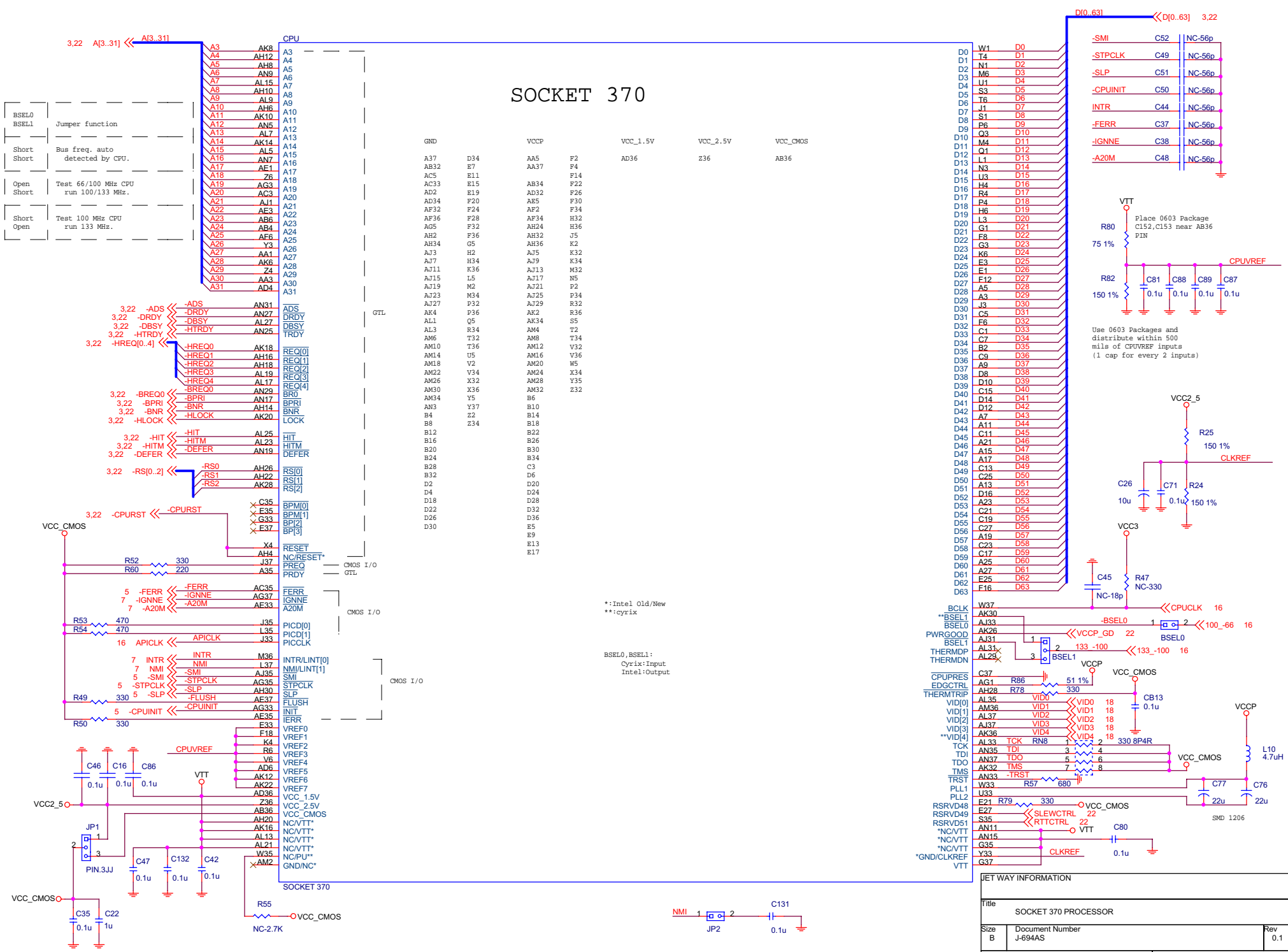

JET WAY INFORMATION		
Title	SOCKET 370 PROCESSOR	
Size	Document Number	Rev
B	J-694AS	0.1
Date:	Thursday, November 23, 2000	Sheet 2 of 22

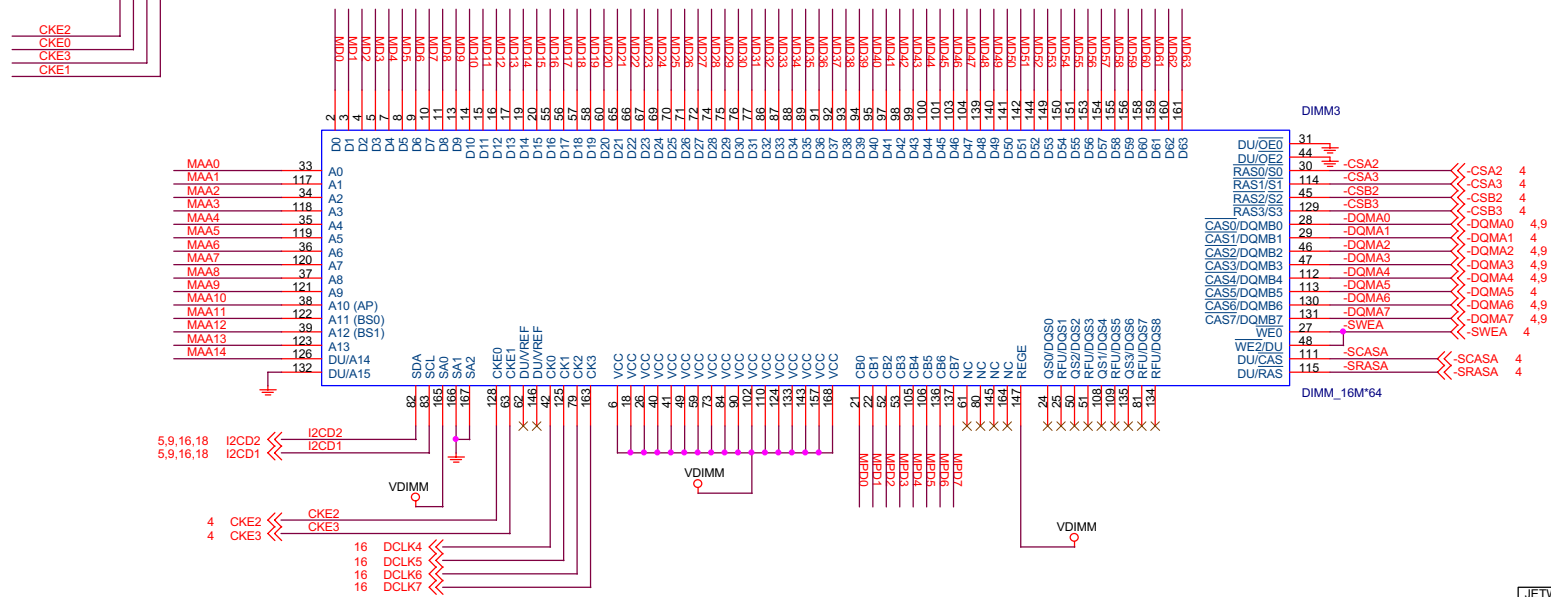
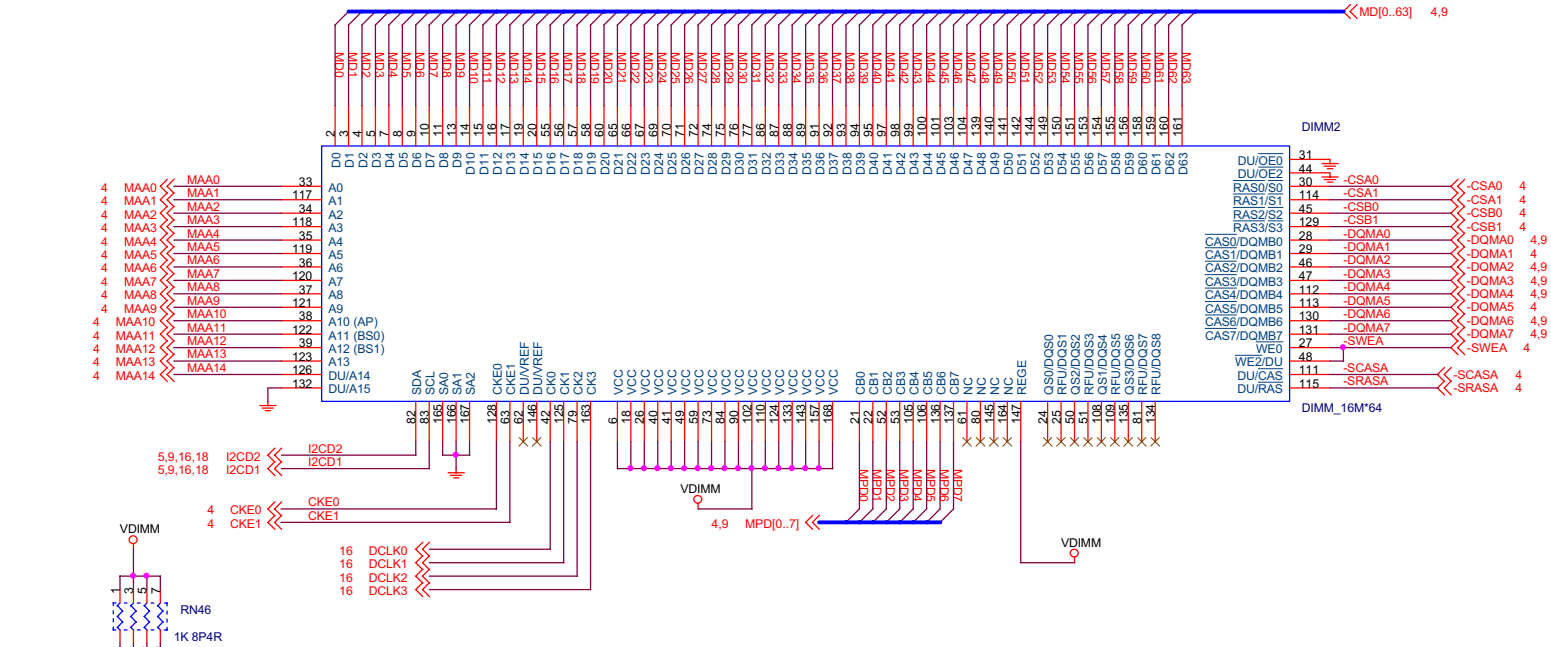

JETWAY INFORMATION			
Title			
SDRAM			
Size	Document Number	Rev	
C	J-694AS	0.1	
Date:	Thursday, November 23, 2000	Sheet	8 of 22

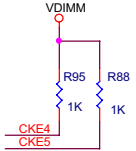
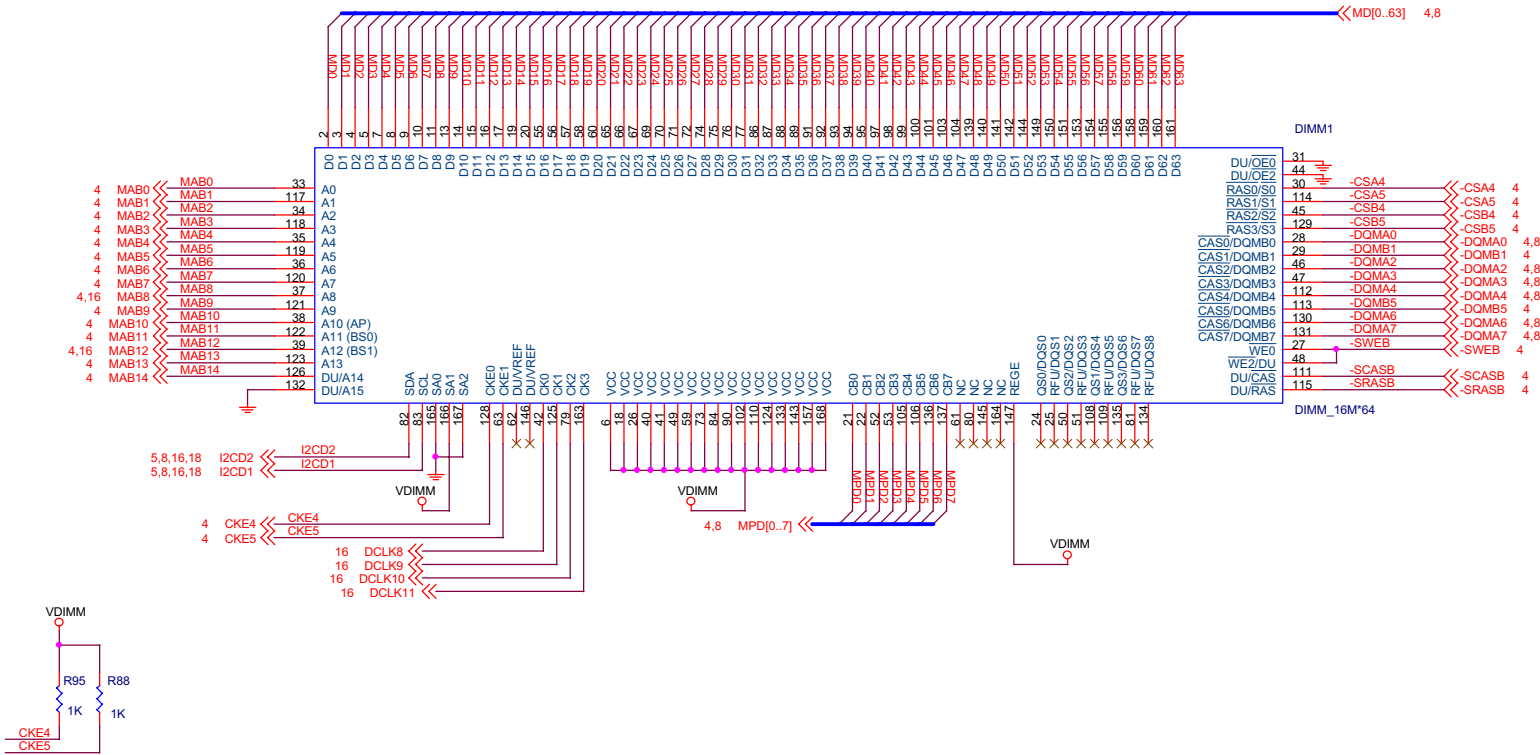

JETWAY INFORMATION			
Title SDRAM			
Size C	Document Number J-694AS		Rev 0.1
Date:	Thursday, November 23, 2000	Sheet	9 of 22

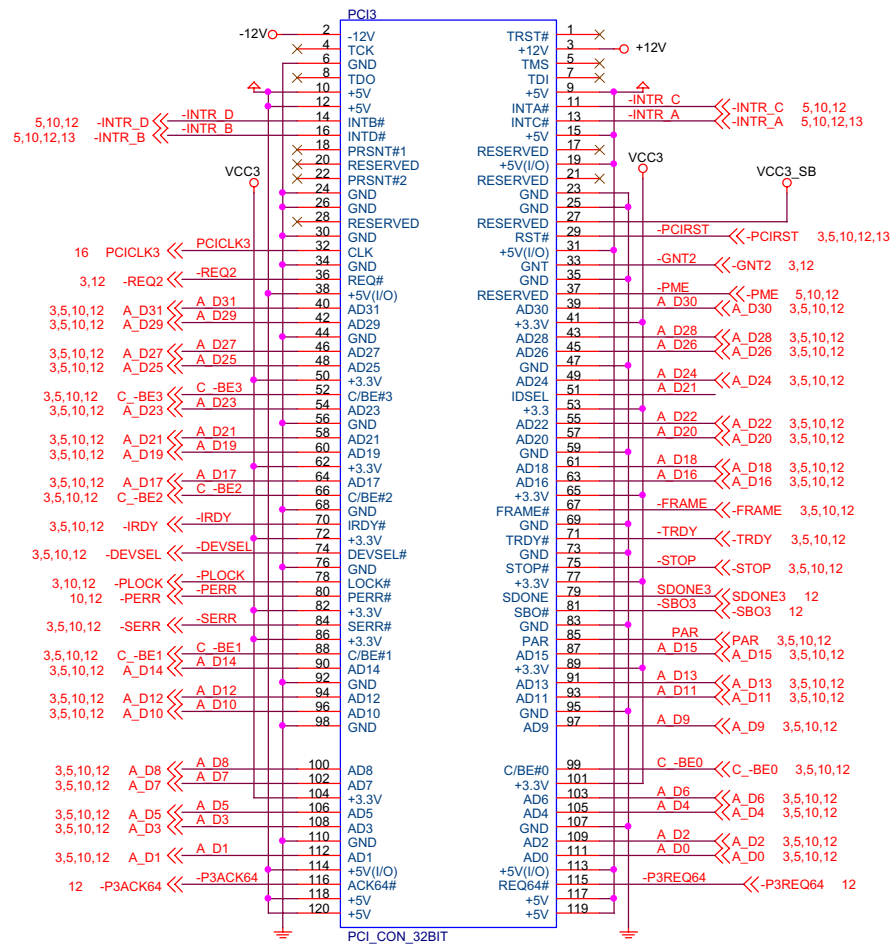

AD: 21
C, D, A, B

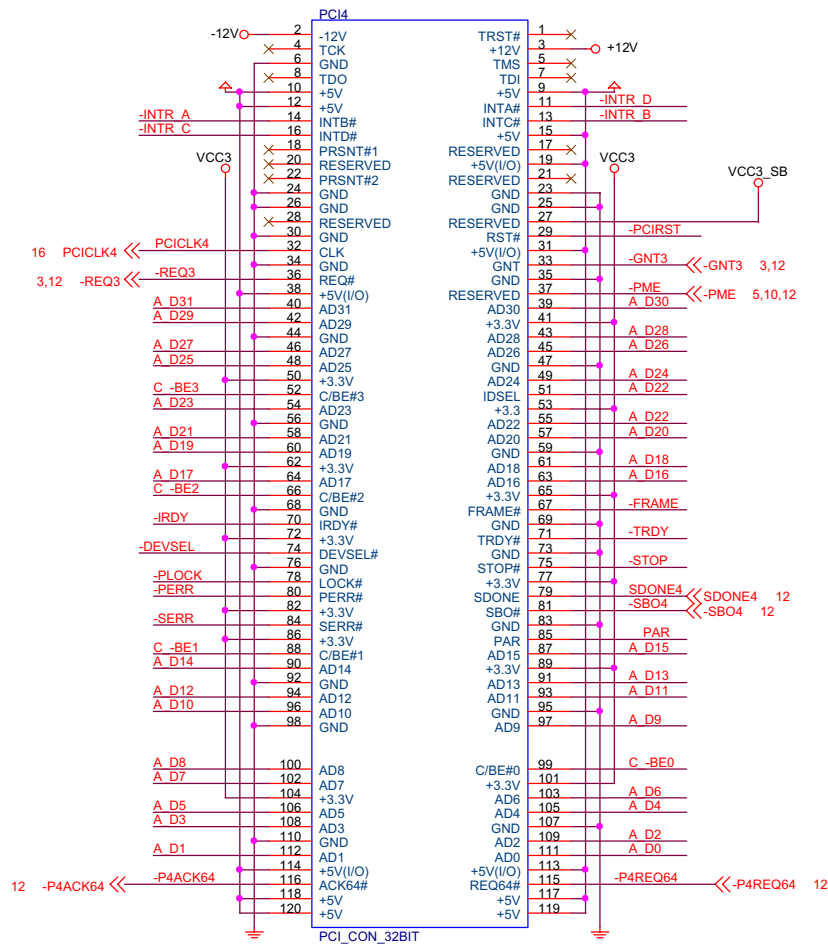
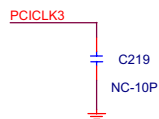

AD: 22
D, A, B, C

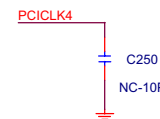

JETWAY INFORMATION		
Title PCI SLOT		
Size	Document Number J-694AS	Rev 0.1
Date:	Thursday, November 23, 2000	Sheet 11 of 22

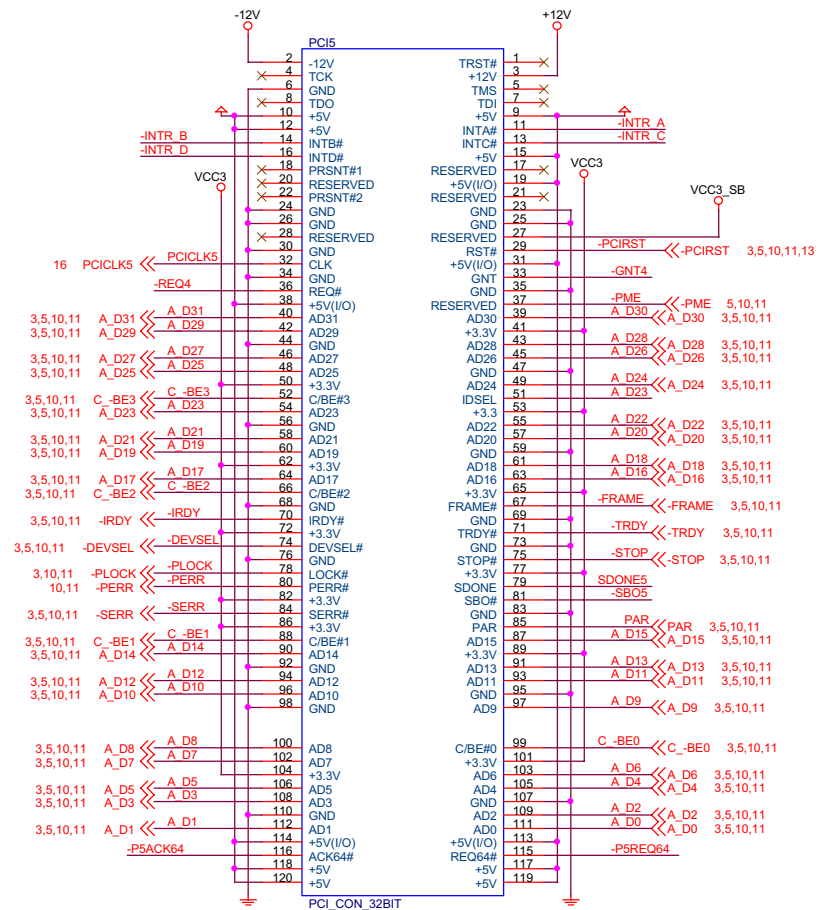
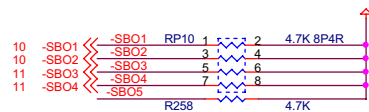
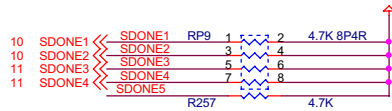
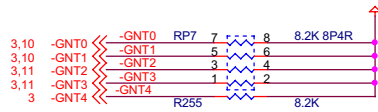
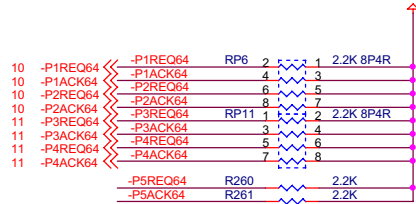
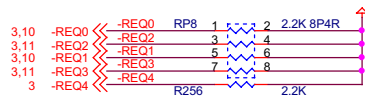
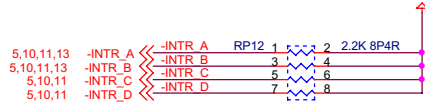
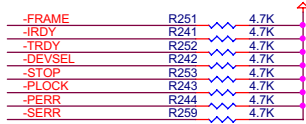

AD: 23
A, B, C, D

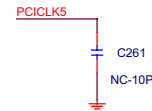

NETWAY INFORMATIN

Title			PCI SLOT		
Size	Document Number			Rev	
C	J-694AS			0.1	
Date:	Thursday, November 23, 2000	Sheet	12	of	22

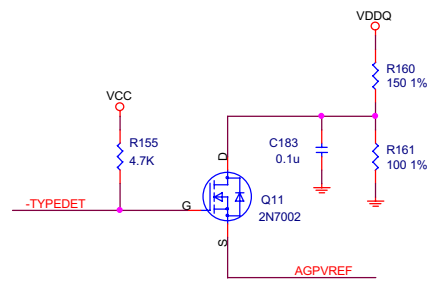
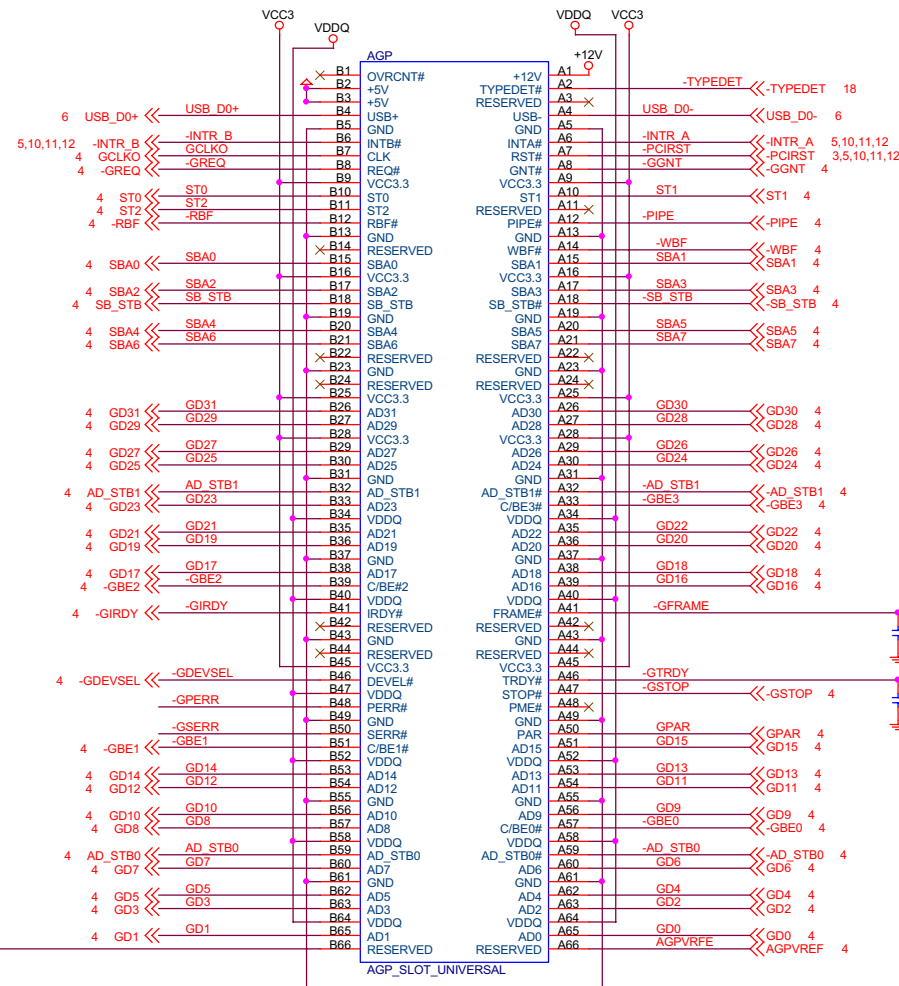
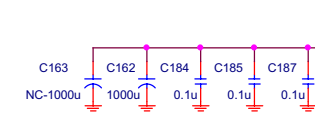
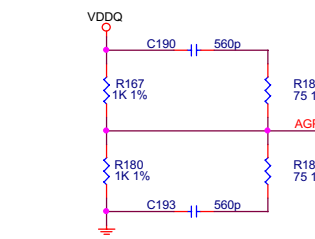
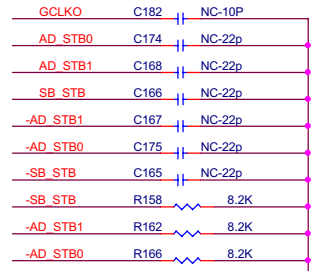
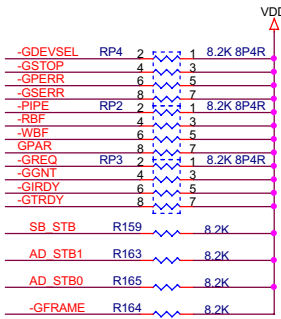

JETWAY INFORMATION			
Title AGP 4X SLOT			
Size C	Document Number J-694AS	Rev 0.1	
Date: Thursday, November 23, 2000	Sheet 13	of 22	

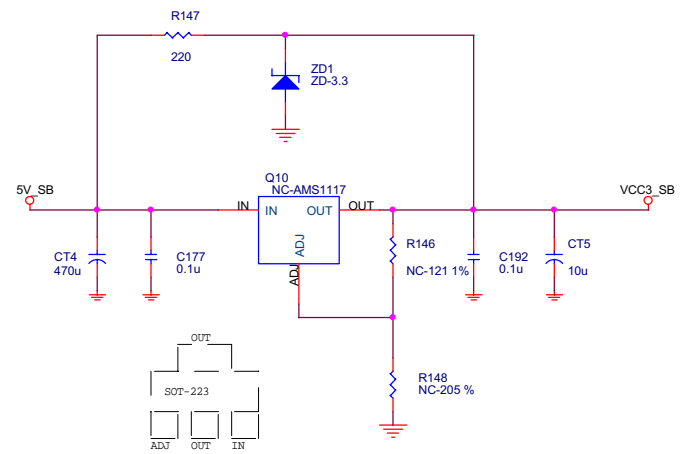
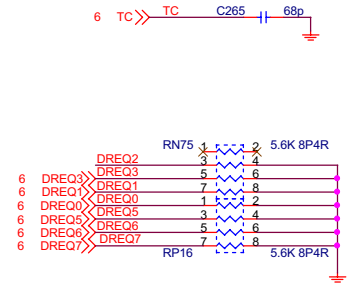
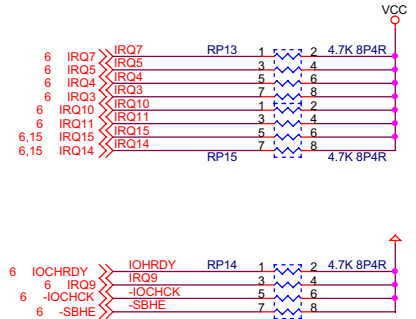
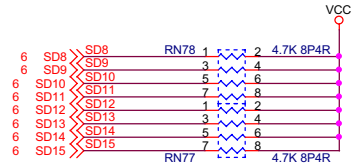
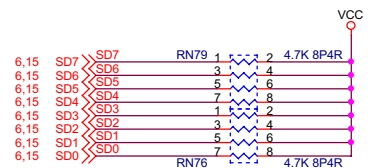
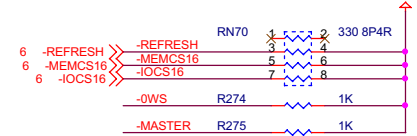
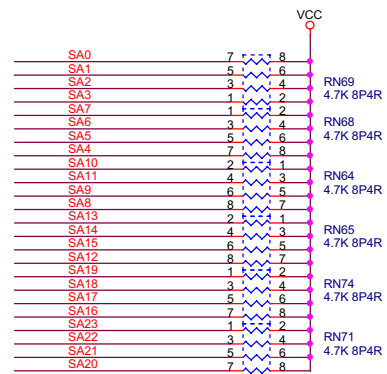
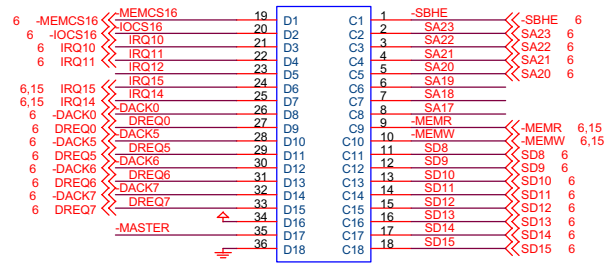
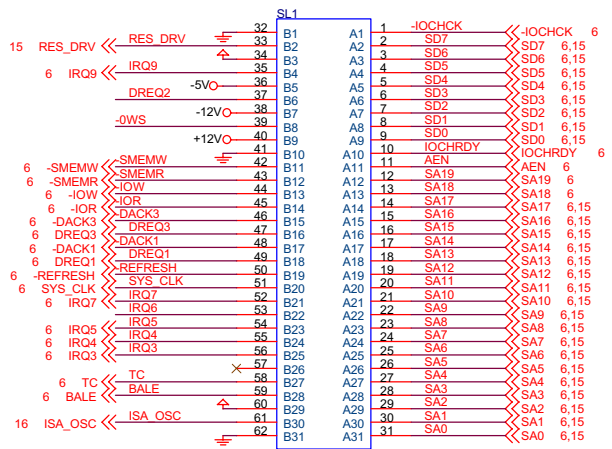

JETWAY INFORMATION			
Title ISA PULL UP RESISTANCE			
Size C	Document Number J-694AS	Rev 0.1	
Date Thursday, November 23, 2000	Sheet 14	of 22	

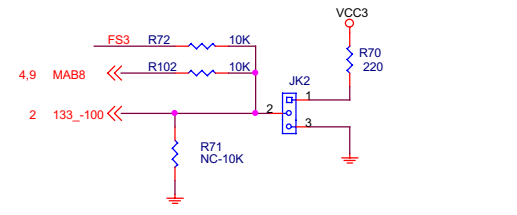
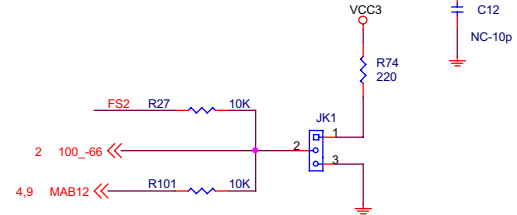
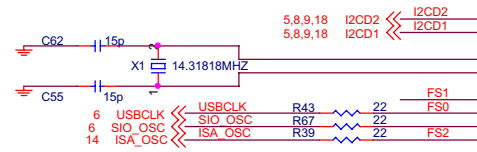
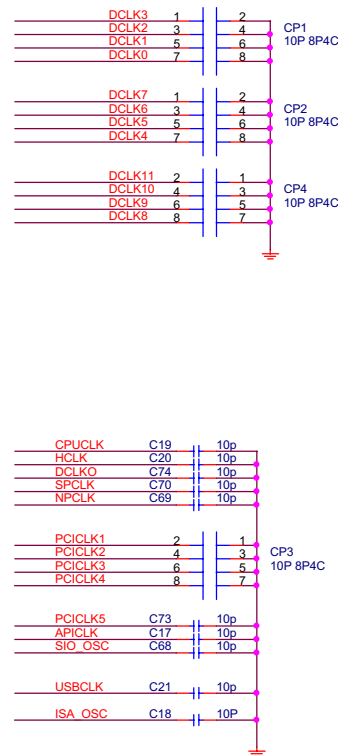
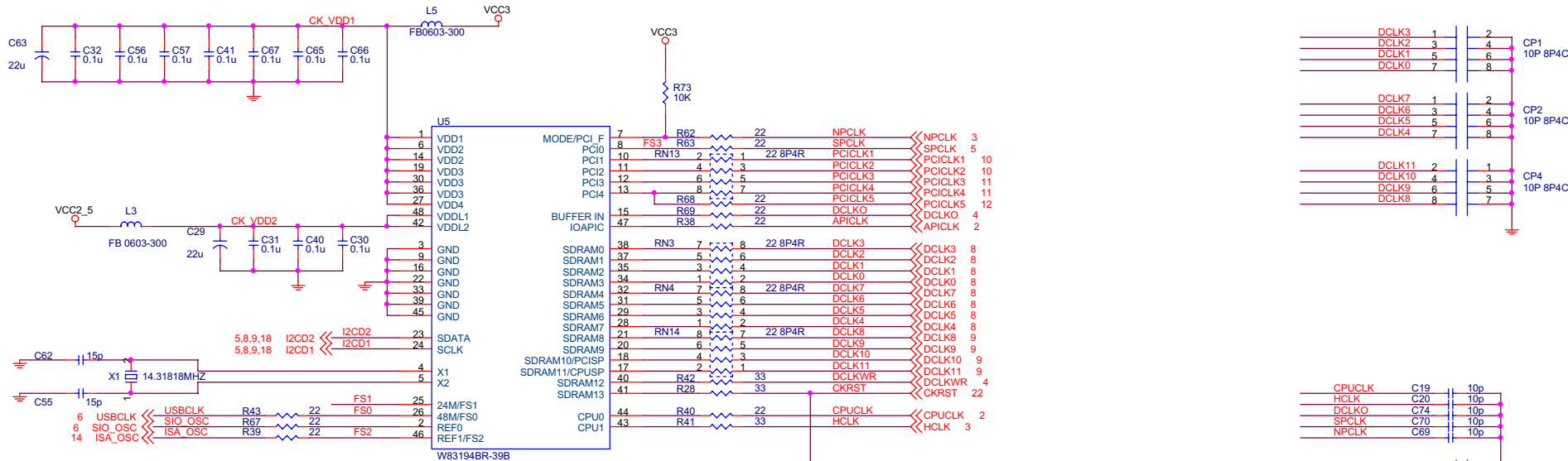

JK2	JK1	Bus Frequency
2-3	2-3	66 MHz
2-3	1-2	100 MHz
1-2	1-2	133 MHz

JETWAY INFORMATION.		
Title CLOCK SYNTHESIZER		
Size C	Document Number J-694AS	Rev 0.1
Date: Thursday, November 23, 2000	Sheet 16	of 22

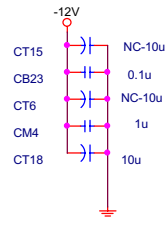
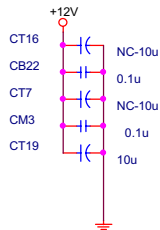
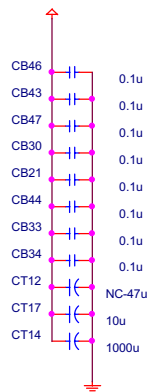
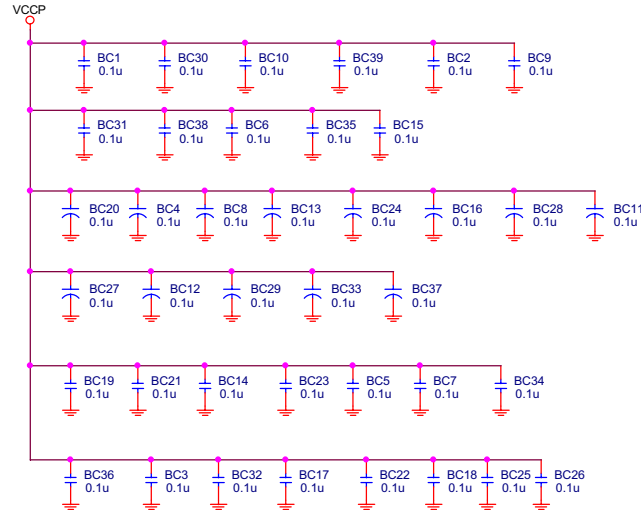
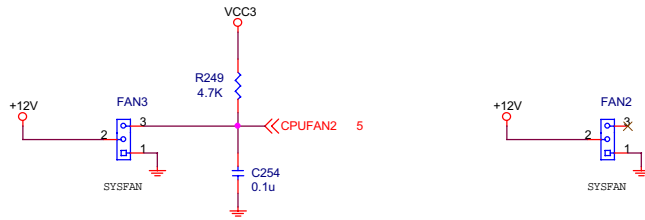
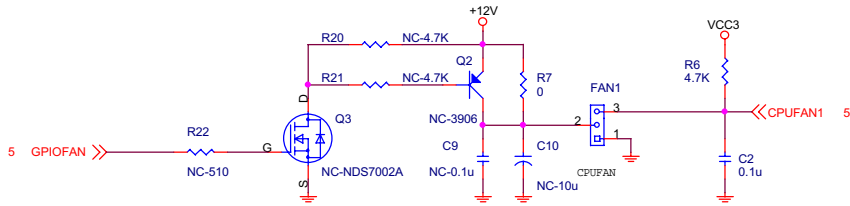
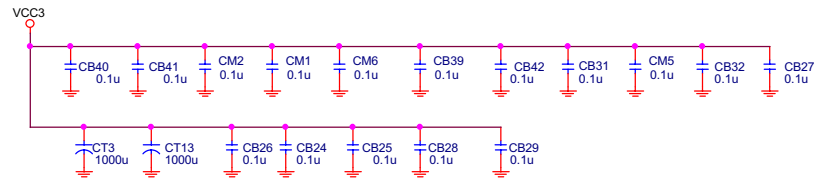
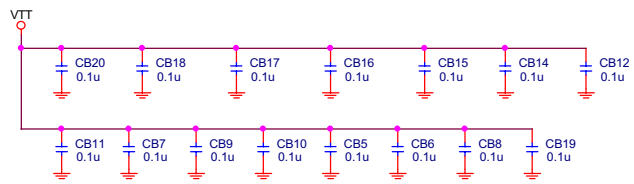

JETWAY INFORMATION

Title POWER CONNECTOR / BYPASS CAPACITOR

Size C	Document Number J-694AS	Rev 0.1
--------	-------------------------	---------

Date: Thursday, November 23, 2000 Sheet 17 of 22

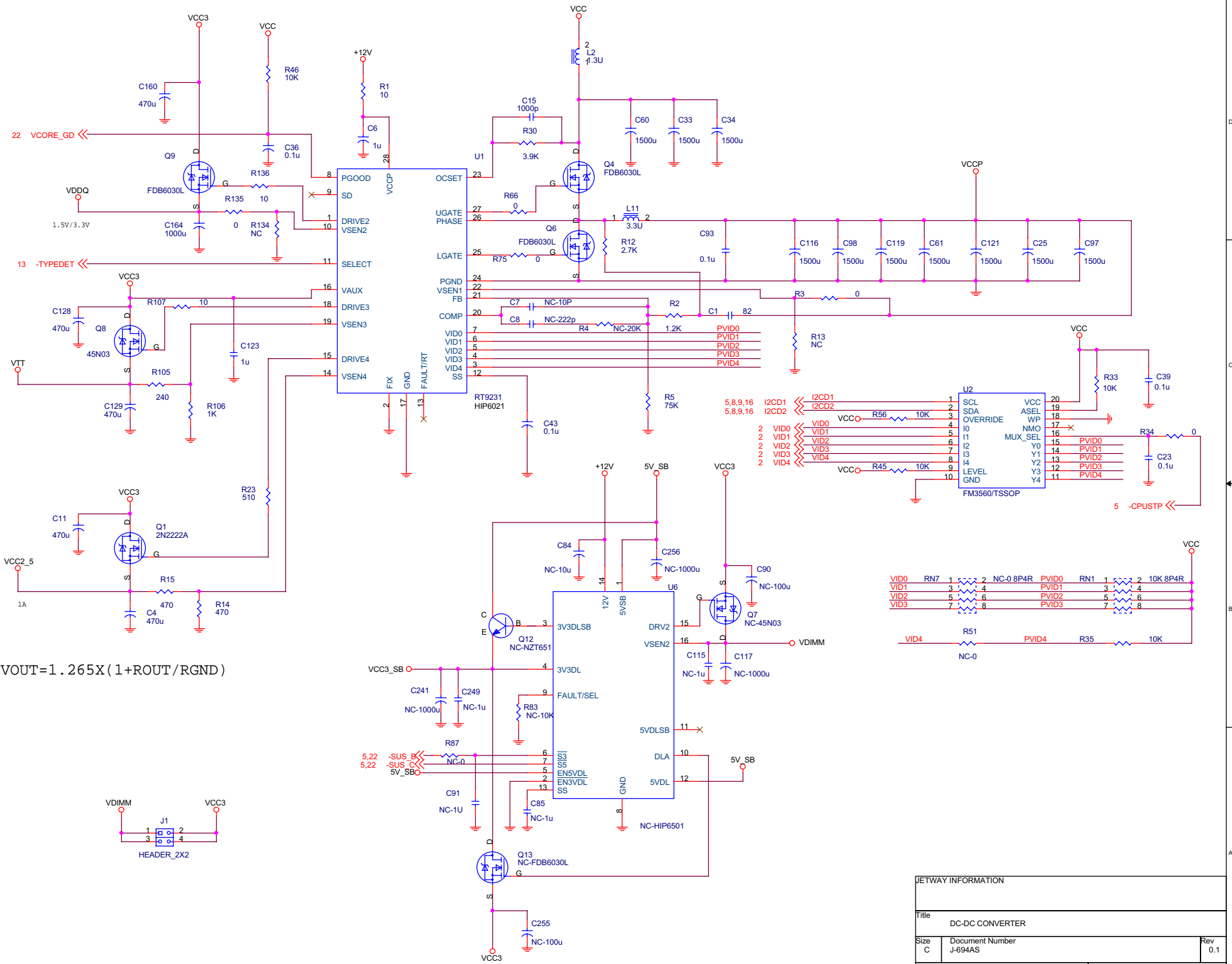

$$V_{OUT} = 1.265X(1 + R_{OUT}/R_{GND})$$

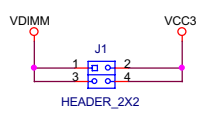

JETWAY INFORMATION			
Title DC-DC CONVERTER			
Size C	Document Number J-694AS		Rev 0.1
Date: Thursday, November 23, 2000	Sheet 18	of 22	

RING IN

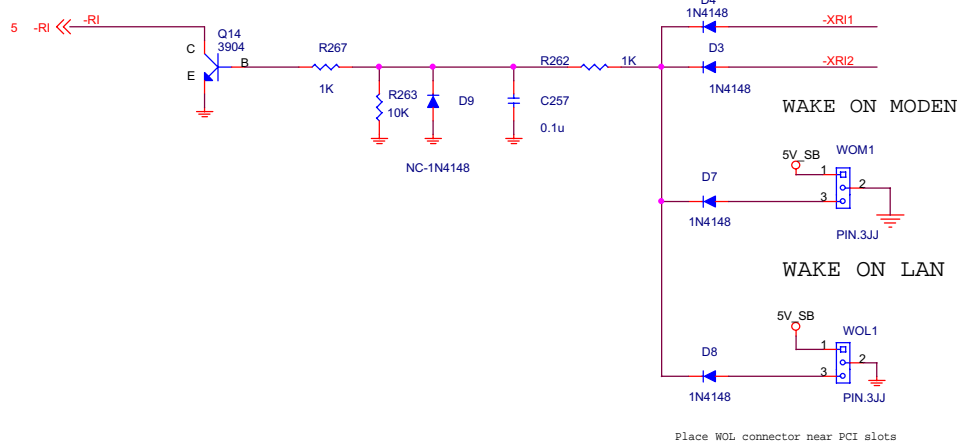

COM1 , COM2

with Bipolar drivers and receivers

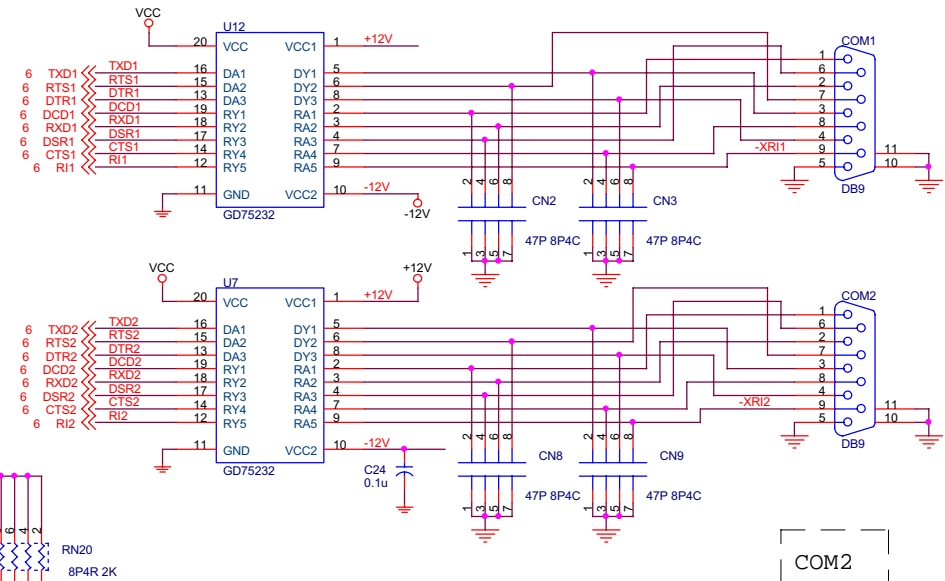

COM1

COM2

PRINTER

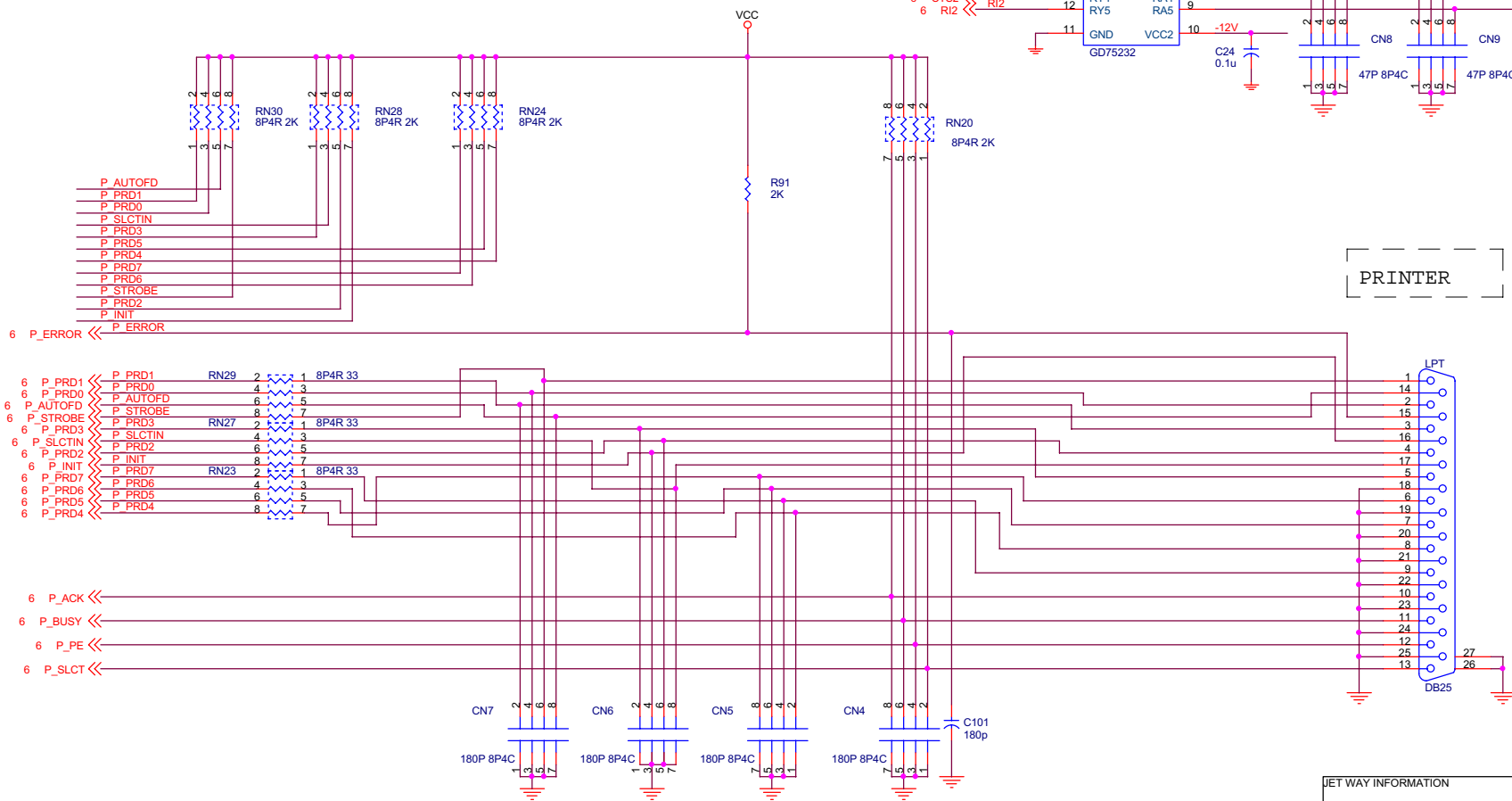

JET WAY INFORMATION		
Title PRINTER / COM PORT		
Size	Document Number J-694AS	Rev 0.1
Date:	Thursday, November 23, 2000	Sheet 19 of 22

CD_IN

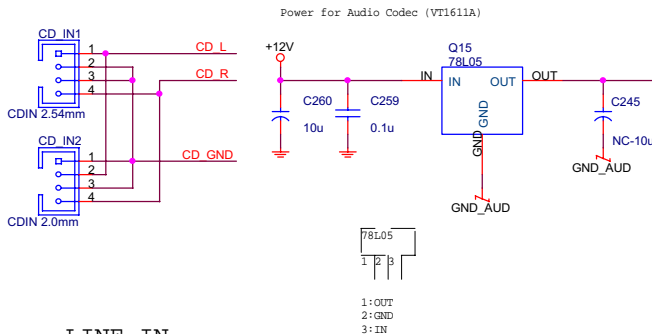

LINE_IN

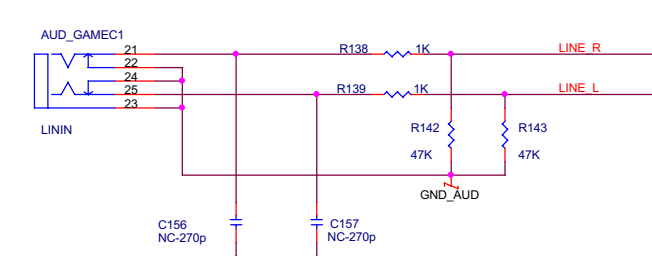

SPEAK_IN

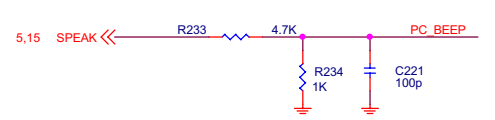

MIC_IN

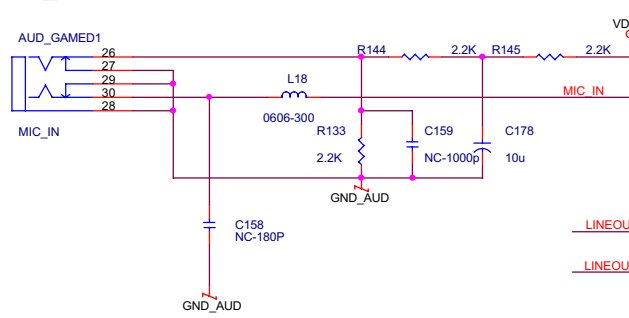

LINE_OUT

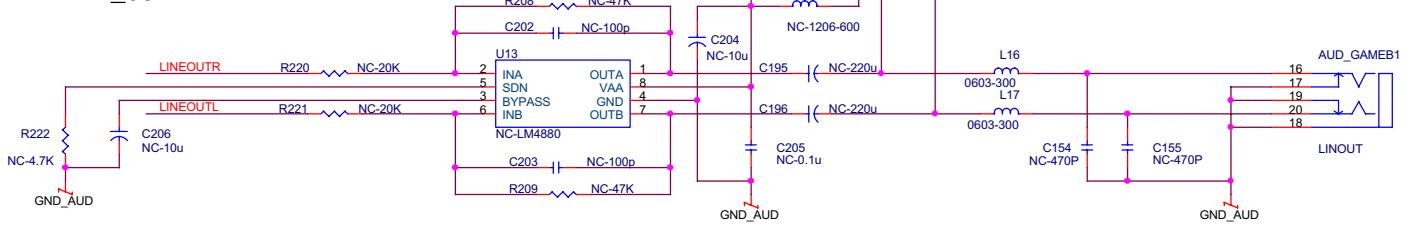

GAME PORT

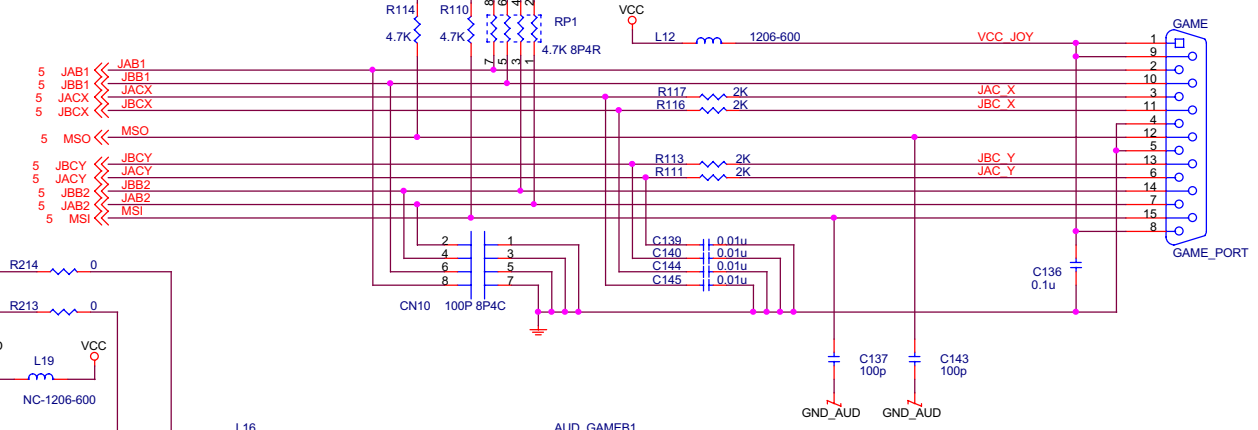

JET WAY INFORMATION

Title		
AC'97 CODEC & AUDIO/GAME PORT		
Size	Document Number	Rev
C	J-694AS	0.1
Date:	Thursday, November 23, 2000	Sheet 20 of 22

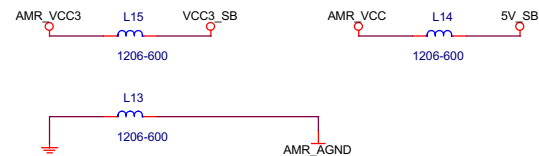
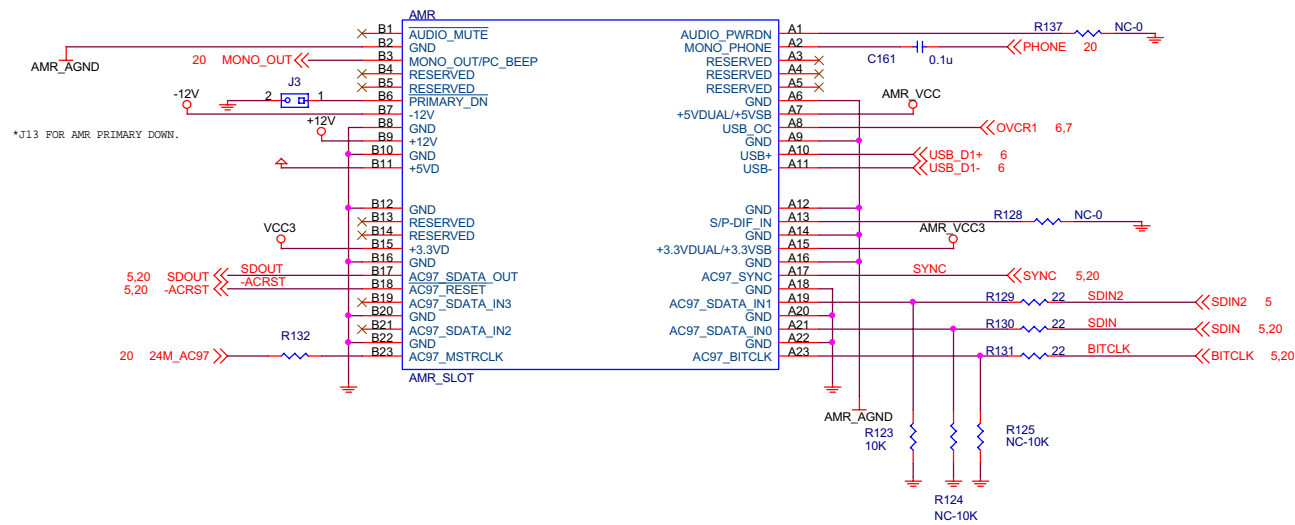

JETWAY INFORMATION			
Title			
ARM SLOT			
Size	Document Number	Rev	
C	J-694AS	0.1	
Date:	Thursday, November 23, 2000	Sheet	21 of 22

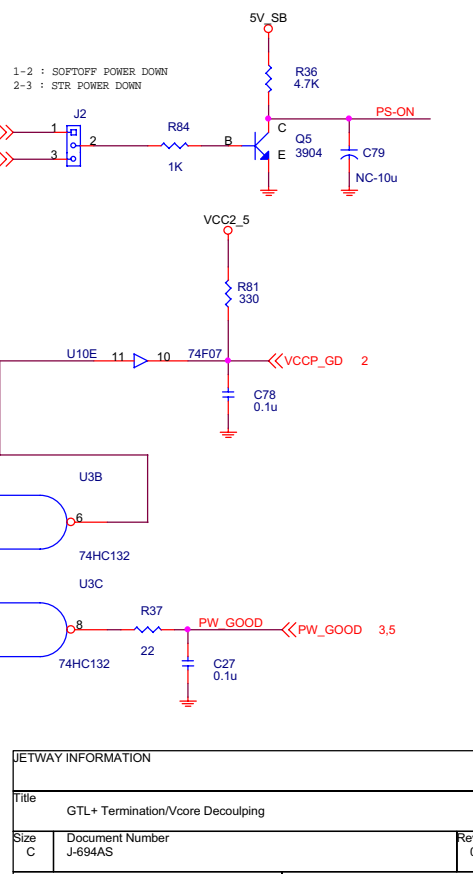
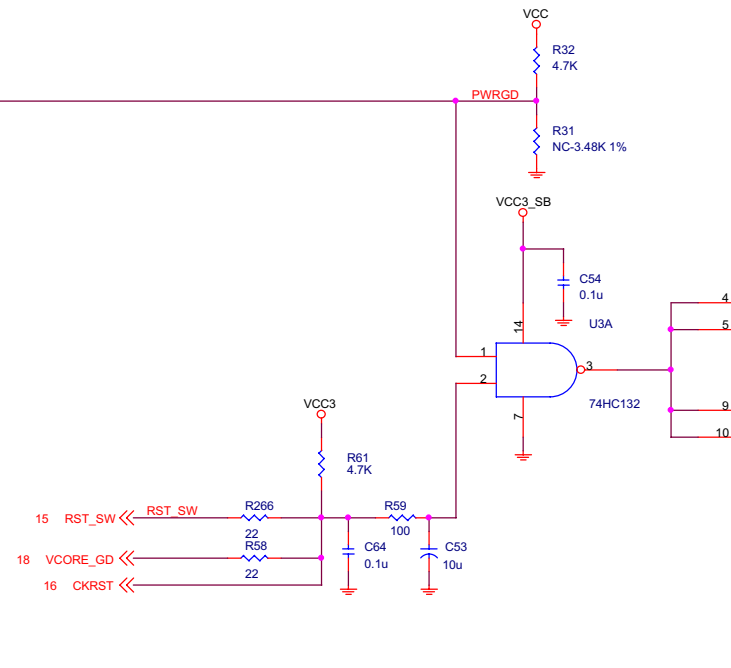
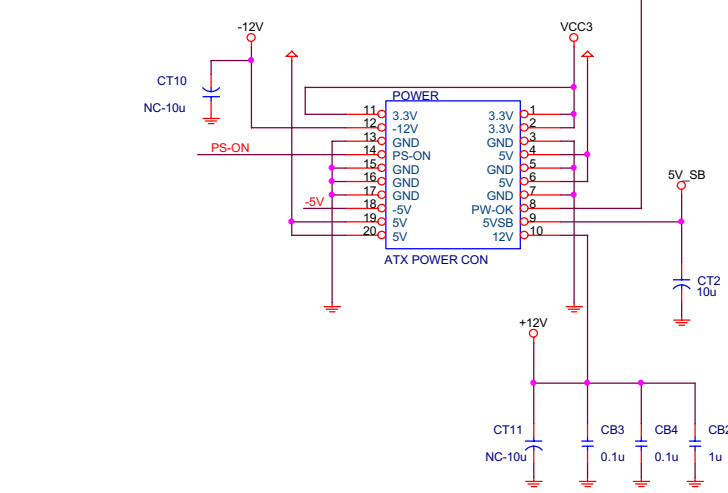
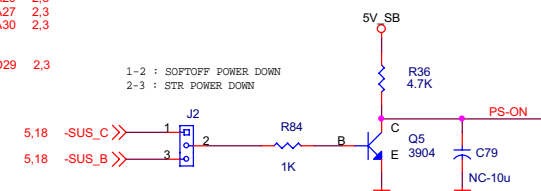
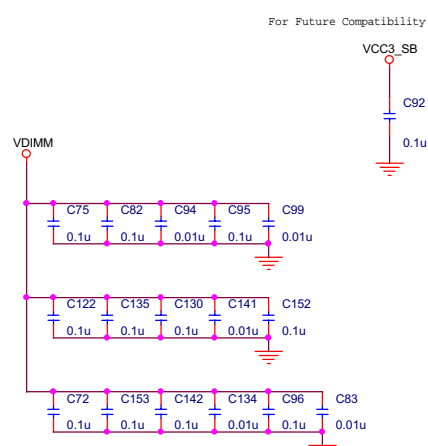
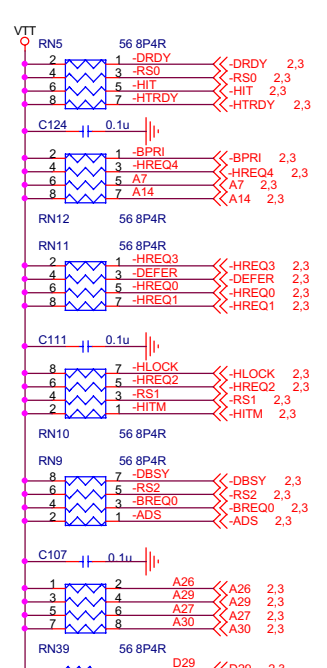
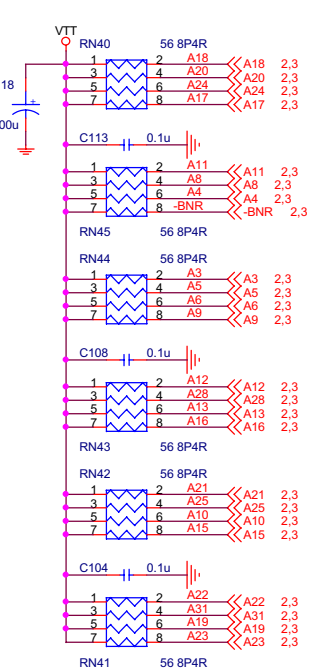
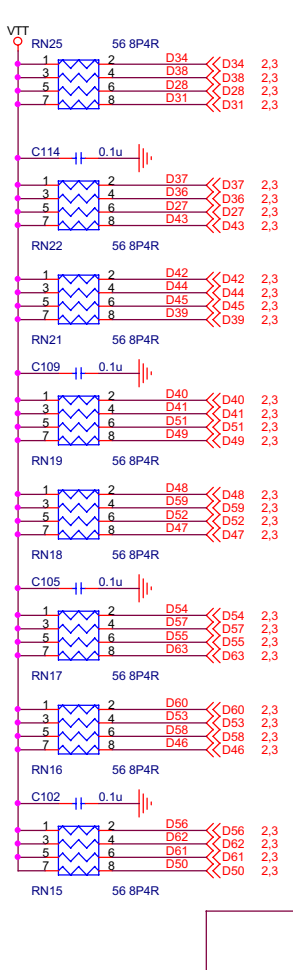
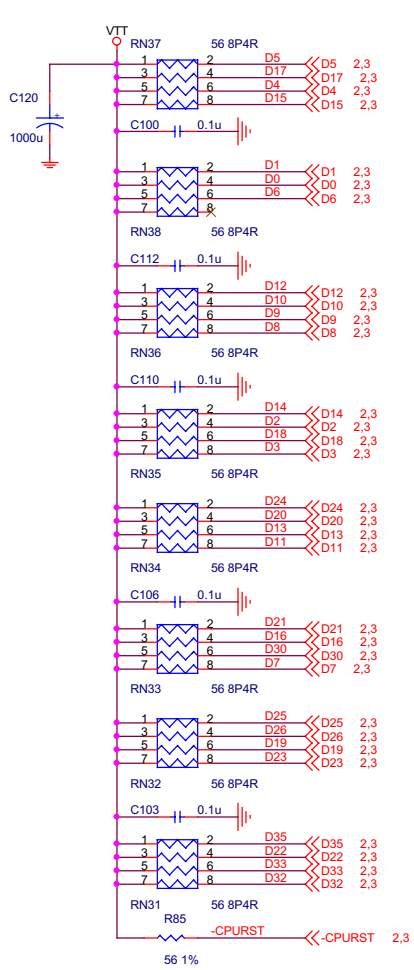

JETWAY INFORMATION		
Title	GTL+ Termination/Vcore Decoupling	
Size	Document Number	Rev
C	J-694AS	0.1
Date:	Thursday, November 23, 2000	Sheet 22 of 22